

ALL TERRAIN CRANE

ATF130G-5

型式	SPEC. No.	最 大 定 格 総 荷 重	ブーム+ジブ	ブーム長さ	ジブ長さ	キャリア	公道走行時の 車両総重量
ATF130G-5	ATF-130G-1-90102	130トン	6段ESP	12.8m~60.0m	———	FAUN ATF130G-5	※ 約38.1トン
			6段ESP+3段FLJ	43.0m~60.0m	7.4m~17.4m		

※旋回台付きのキャリア

ESP：イージー・スカイピン機構(1本シリンダ伸縮方式)
FLJ：フルオートラフティングジブ

諸 元

■クレーン

ブーム	12.8m	130,000 kg × 2.7m (2×12本掛、アタッチメント付)
	17.1m	86,900 kg × 4.0m (13本掛)
	21.4m	86,900 kg × 4.0m (13本掛)
	25.8m	70,000 kg × 5.0m (11本掛)
	30.1m	54,300 kg × 4.5m (8本掛)
	34.4m	44,000 kg × 5.0m (7本掛)
	38.7m	32,800 kg × 7.0m (5本掛)
	43.0m	27,100 kg × 9.0m (4本掛)
	47.4m	21,400 kg × 11.0m (3本掛)
	51.7m	16,600 kg × 12.0m (3本掛)
	56.0m	13,200 kg × 14.0m (3本掛)
60.0m	10,600 kg × 16.0m (3本掛)	
シングルトップ		7,300 kg (1本掛)
フルオート ラフィングジブ (FLJ)	1.6m+7.4m FLJ	7,300 kg × 26.0m (1本掛)
	1.6m+12.4m FLJ	4,300 kg × 28.0m (1本掛)
	1.6m+17.4m FLJ	3,300 kg × 20.0m (1本掛)
最大地上揚程	ブーム	61m (10.6 t)
	FLJ	78m (2.8 t)
最大作業半径	ブーム	56.0m (2.0 t)
	FLJ	64.0m (0.8 t)
ブーム・ジブ 長さ	ブーム	12.8m ~ 60.0m
	FLJ	1.6m + 7.4m~17.4m
ブーム・ジブ 形	ブーム	箱型6段油圧伸縮式、各段ピンロック方式
	FLJ	箱型3段同時伸縮式 オフセット5°~60°油圧無段階傾斜式
ブーム・ジブ 伸縮装置	ブーム	先端ブーム取付横折曲格納式
	FLJ	複動油圧シリンダ直押式1本 ワイヤロープ式伸縮装置1基
ブーム伸長速度		47.2m/400s
フック		90tフック(13本掛) 50tフック(7本掛) 22tフック(3本掛) 7.3tフック(1本掛)
巻上装置		油圧モータ駆動遊星歯車減速式、自動ブレーキ、 高低速切換装置付、シングルウインチ2基、 圧力補償付流量調整弁付
ワイヤロープ	主巻	径21mm × 長さ360m、非自転性ワイヤロープ
	補巻	径21mm × 長さ250m、非自転性ワイヤロープ
巻上速度	主巻	120m/min (4層)
	補巻	120m/min (4層)
ブーム起伏装置		複動油圧シリンダ直押式1本、 圧力補償付流量調整弁付
ブーム上げ速度		-1.0° ~ 85.0°/50s
旋回装置		油圧モータ駆動遊星歯車減速式 ボール式スイングベアリング 手動スイッチ式ブレーキ 手動操作式旋回ロック
旋回角度		360°連続
旋回速度		1.4 min ⁻¹
カウンタウエイト		40t、28t、25t、15t、6t、0t
アウトリガ		全油圧式H型 張出幅：最大7.5m、 中間6.2m、5.0m、4.1m、最小2.5m スライド・ジャッキ各個操作装置付 スライドロック用ピン付 スライド格納式フロート
上部エンジン	形 式	ベンツ OM904LA 水冷4サイクル直列4気筒 直接噴射式 排気ターボ過給 インタークーラ付 ディーゼルエンジン
	総排気量	4.25L
	最高出力	129kW [175PS] / 2,200min ⁻¹ [rpm]
	最大トルク	675N・m [68kgf・m] / 1,200min ⁻¹ [rpm]
燃料タンク容量		220L
油圧ポンプ		高圧可変ピストンポンプ2個、 高圧ピストンポンプ1個、 高圧キャボンパ2個

安全装置	過負荷防止装置 (AML) 作業範囲制限機能 旋回範囲制限機能 旋回自動停止機能 ブーム起伏緩停止機能 フック移動量表示機能 カウンタウエイト組み合わせ検出装置 サブウインチ検出装置 個別検出式アウトリガ張出幅自動検出装置 巻過防止装置 捨巻確保装置 水準器 玉掛けロープはずれ止め 旋回ロック装置 油圧安全弁 油圧ロック装置 (伸縮・起伏・巻上・ジャッキ) ウインチドラム回転計
付属装置	カウンタウエイト着脱装置 ブーム着脱装置 速度調整装置 (起伏・旋回・ウインチ・ジブチルト) 風速計 リフトアジャスタ オイルクーラー AML外部表示灯 旋回音声警報装置 ドラム視認モニタ クレーンキャブエアコン ラジオ 携帯通信装置 (HELLO-NET Owner's Site)
オプション	1.5tウエイト、拡声器

■キャリア

最高速度	85 km/h	
登坂能力	tanθ = 0.7	
最小回転半径	9.31m	
全長	12,850 mm	
全幅	2,780 mm	
全高	4,020 mm	
軸距	2,560 mm + 1,650 mm + 2,000 mm + 1,700 mm	
輪距	2,310 mm	
車両総重量	全重量	38,100 kg (人員2名)
	前軸	18,580 kg (1軸 + 2軸)
	後軸	1,550 kg (3軸) 17,970 kg (4軸 + 5軸)
乗員定員	2名	
エンジン	形 式	ベンツOM502LA 水冷4サイクルV型8気筒直接噴射式 排気ターボ過給 インタークーラ付 ディーゼルエンジン
	総排気量	15.928 L
	最高出力	390kW [530PS] / 1,800min ⁻¹ [rpm]
	最大トルク	2,400N・m [245kgf・m] / 1,300min ⁻¹ [rpm]
燃料タンク容量	500 L	
変速機	形 式	ZF ASトロニック 自動変速式インターダブレーキ付
	段	前進12段、後退2段
駆動方式	10 × 6 … オンロード 10 × 8 … オフロード (デフロク機構付)	
車軸形式	5軸全浮動式	
懸架方式	全軸ハイドロニューマチック、レベリング調整付 サスペンションストローク: +160mm、-110mm	
ステアリング	左ハンドル、非常ステアリングポンプ付2系統式 パワーステアリング、特殊ステアリングモード付	
ブレーキ	主ブレーキ	空気式全輪制動、2系統式
	駐車ブレーキ	3・4・5軸 (6輪) 制動スプリング式
	補助ブレーキ	変速機内蔵式流体式リターダ、排気ブレーキ
タイヤ	445 / 95R25 (全輪)	
バッテリー	12V - 170 Ah × 2 (24V)	
付属装置	エアコン、ラジオ、集中給油装置、 仮眠用ベッド、バックモニタ	

走行

■ 公道走行状態

単位(mm)

● キャリヤ + 旋回体+起伏シリンダ 38.1 t

(公道走行時の注意事項)

1. ブームおよびカウンタウエイト装置を別送し、旋回体を後方向に向け、旋回ブレーキをかけピンロックした状態で走行しなければなりません。
2. 道路運送車両の保安基準による保安基準緩和の認定が必要です。
3. 道路法による特殊車両の通行許可が必要です。基本通行条件 重量: Cが記載された適合証明書を取得していますが、実際の通行経路で申請して許可された条件にしたがって走行しなければなりません。

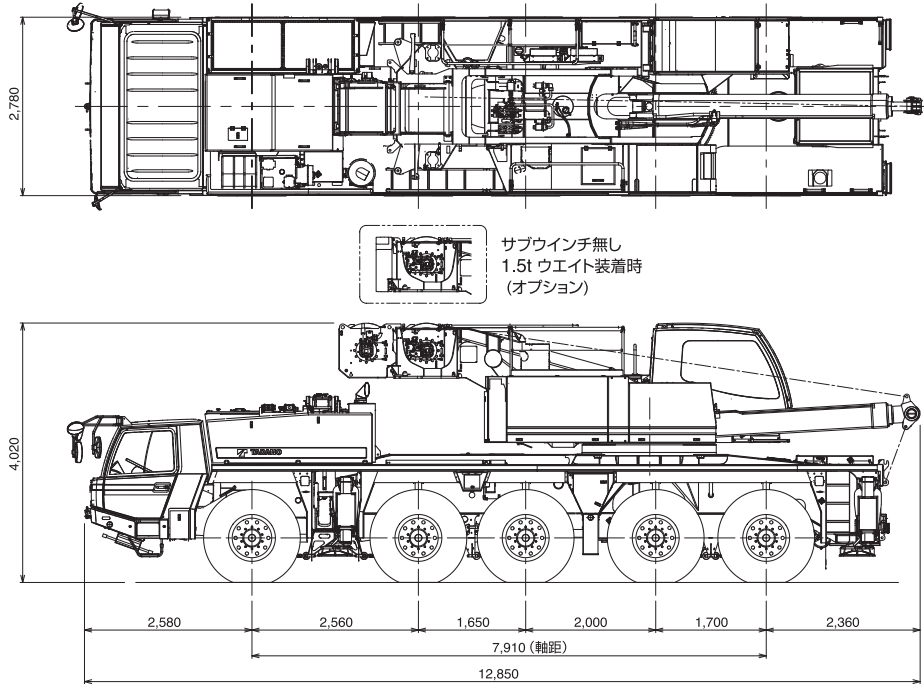

■ 構内移動姿勢

単位(mm)

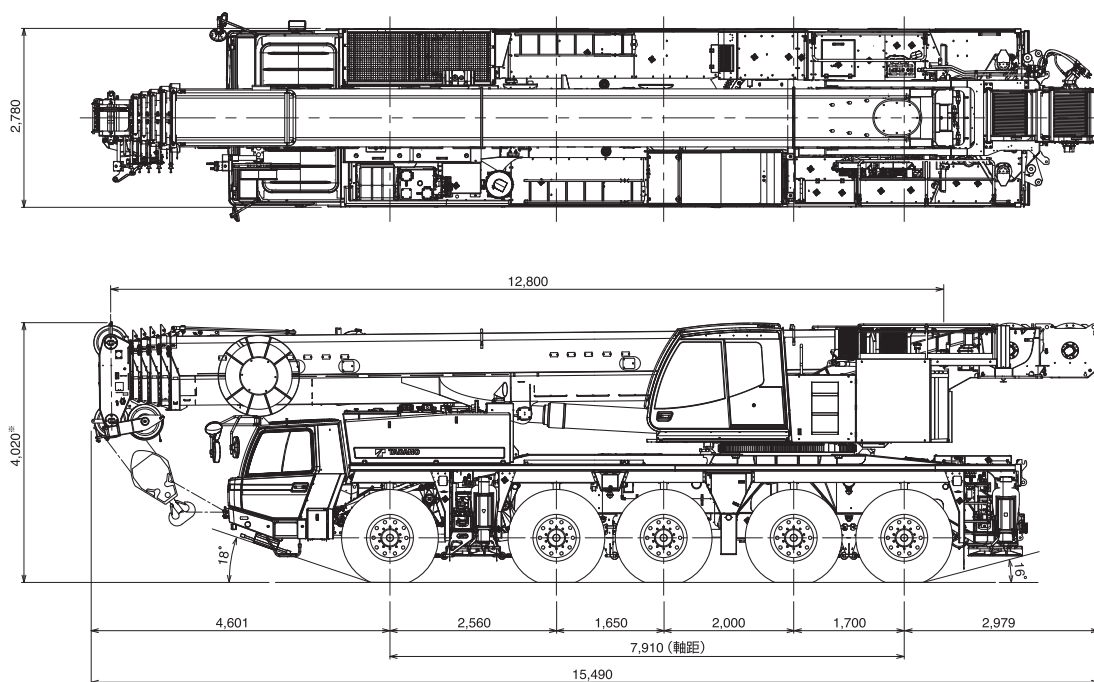

*+160mm、-110mm (サスペンション)

最低地上高: 350mm

走行

■ 最小直角通路幅

単位(mm)

● 公道走行状態

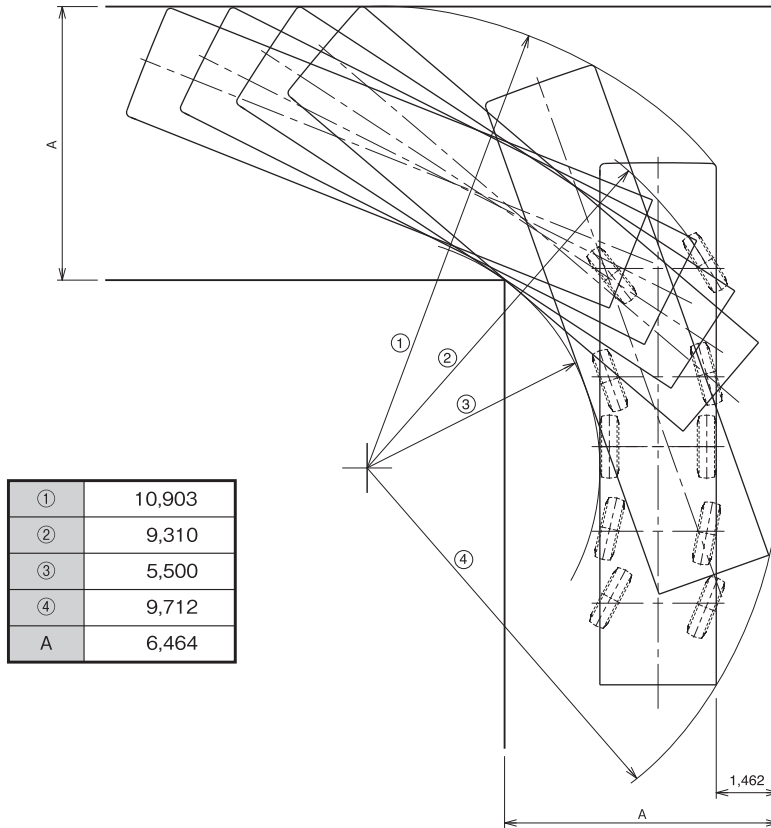

● 構内移動姿勢 (ジブ無し)

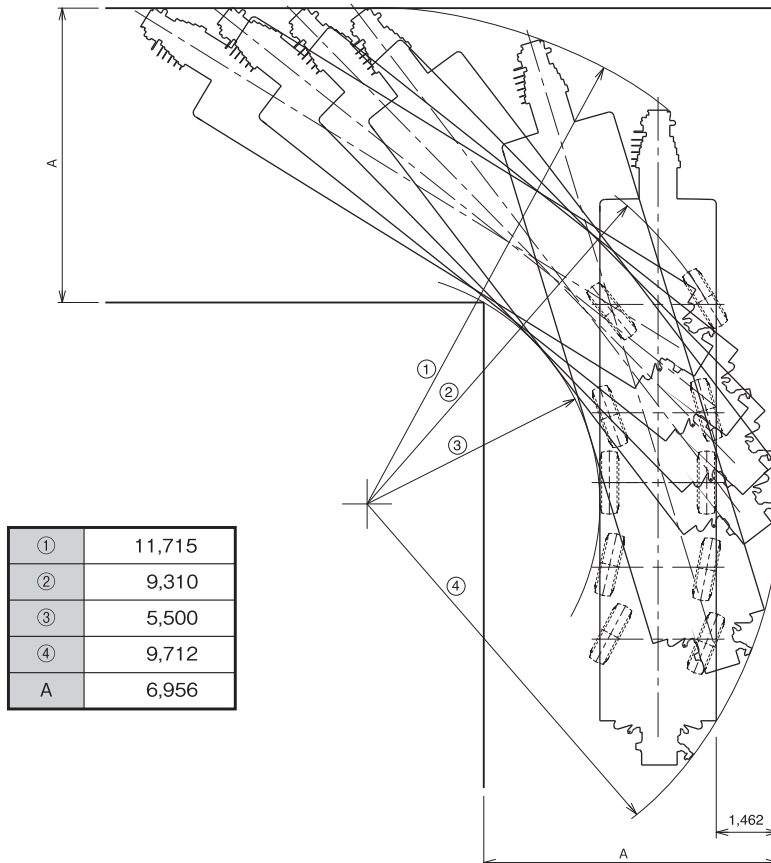

搬 送

■ 分解搬送部品

単位(mm)

● ブーム 15.2 t

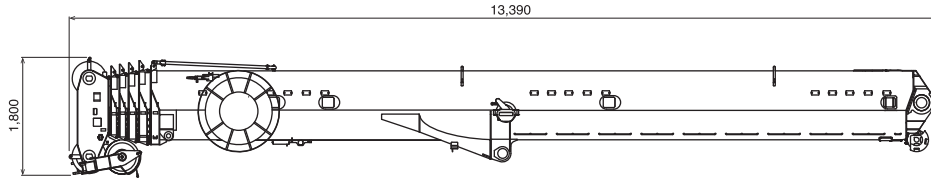

幅 1,650

● フルオートラフィングジブ(FLJ) 2.2 t

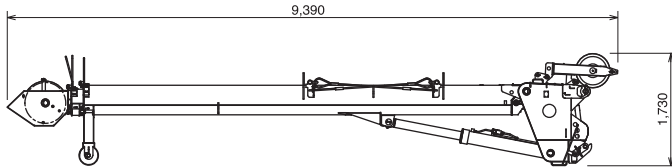

幅 1,090

● アダプタ 0.3 t

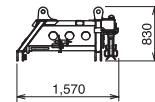

幅 1,350

● カウンタウエイト(C/W)

① 2.7 t × 1個

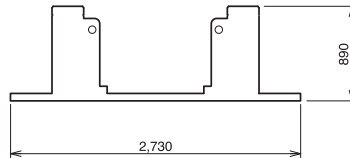

長さ 1,605

② 3.4 t × 1個

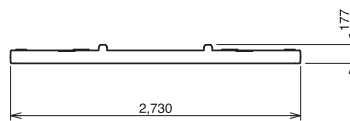

長さ 1,753

③ 8.9 t × 1個

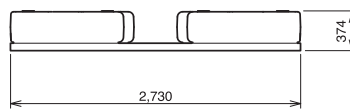

長さ 1,770

④ 10.0 t × 1個

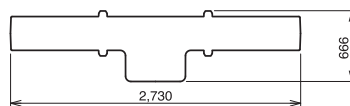

長さ 1,770

⑤ 3.1 t × 1個

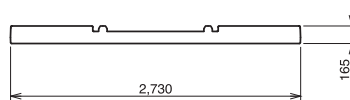

長さ 1,750

⑥ 6.1 t × 2個

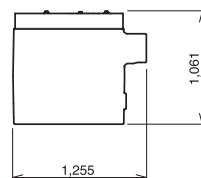

長さ 1,275

● サブウインチ 1.5 t

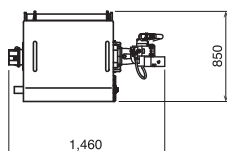

長さ 960

● 1.5t ウェイト (オプション) 1.5 t

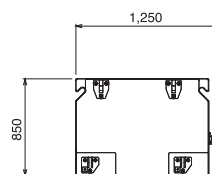

幅 380

その他に付属品があります。

設置

フック寸法

単位(mm)

● フルオートラフィングジブ(FLJ)

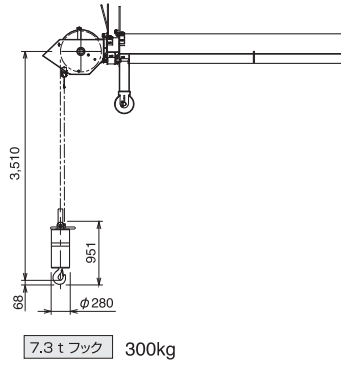

● ブーム

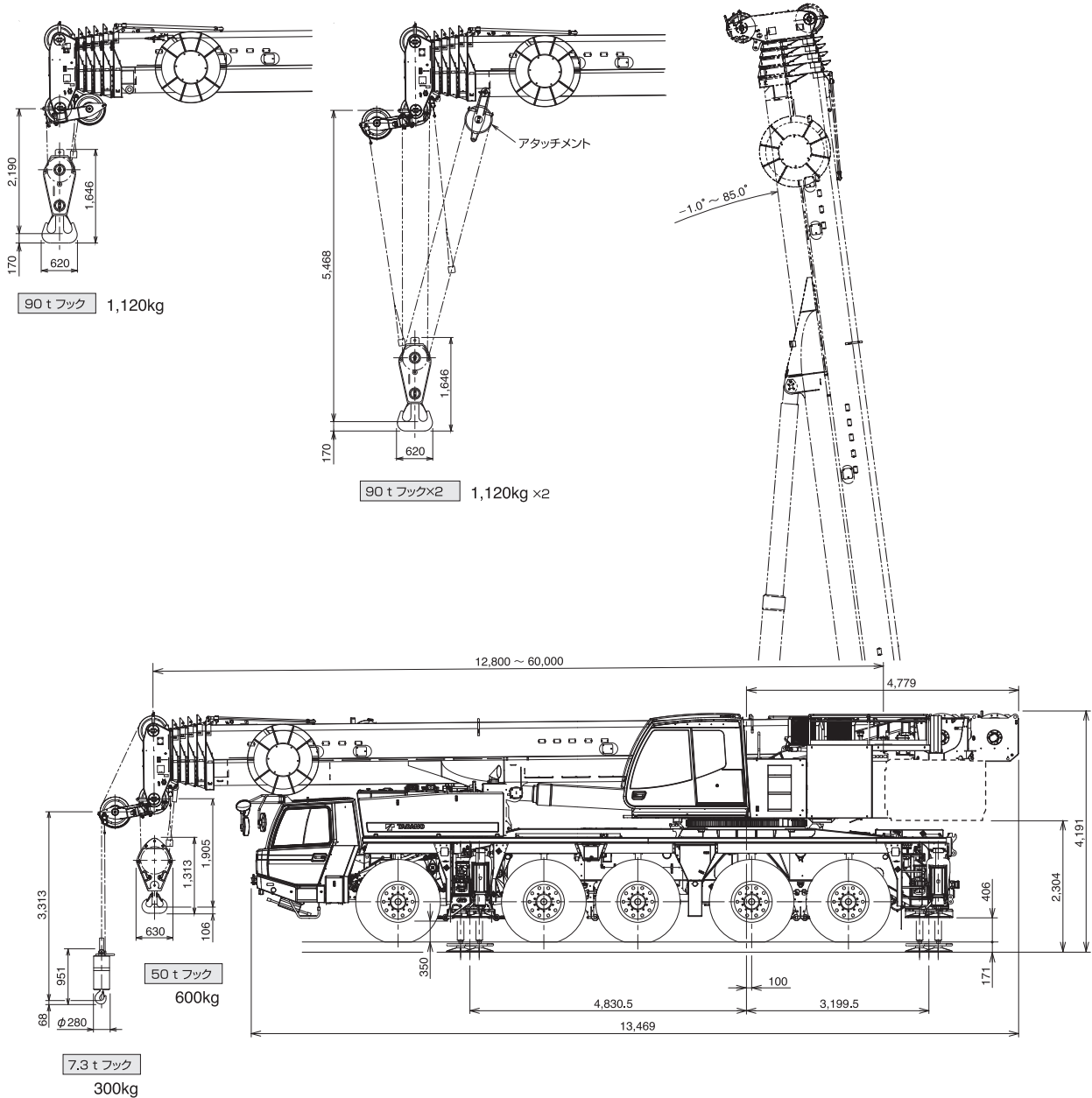

設置

■ アウトリガ張出幅・テールスイング

単位(mm)

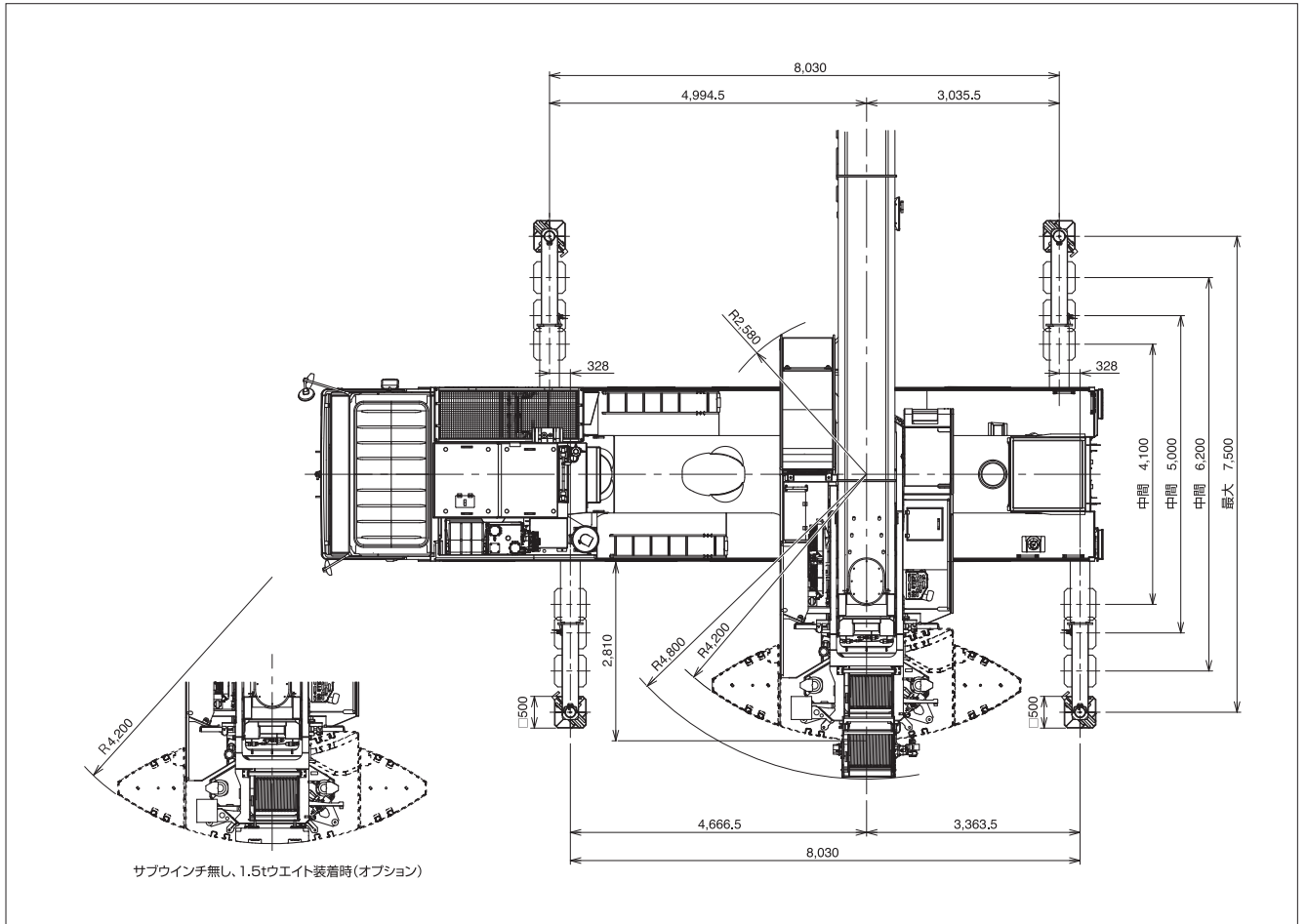

■ カウンタウエイト(C/W)組合せ

6.1 t	①+②
15.0 t	①+②+③
25.0 t	①+②+③+④
28.1 t	①+②+③+④+⑤
40.3 t	①+②+③+④+⑤+⑥×2

● 各部の質量

①	2.7 t
②	3.4 t
③	8.9 t
④	10.0 t
⑤	3.1 t
⑥	6.1 t

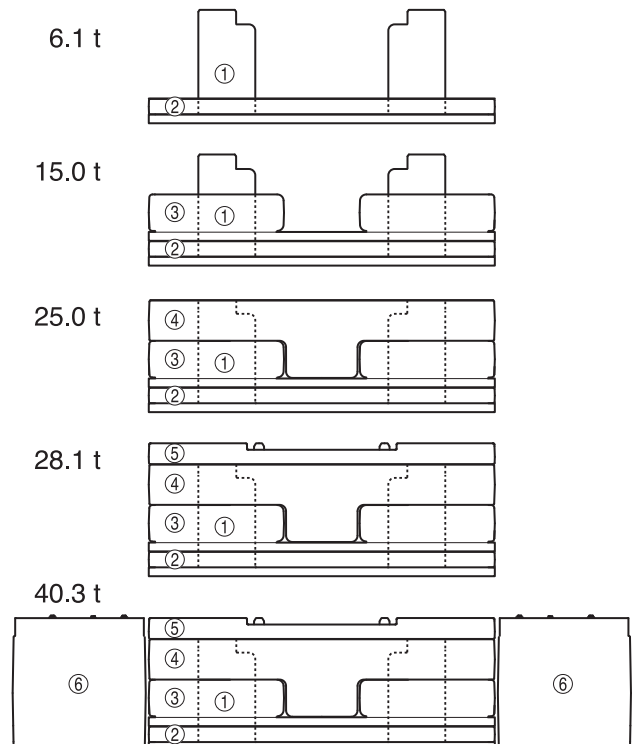
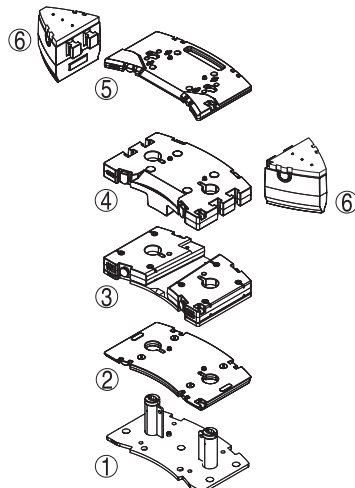

オールテレーンクレーン
ATF130G-5
ブーム

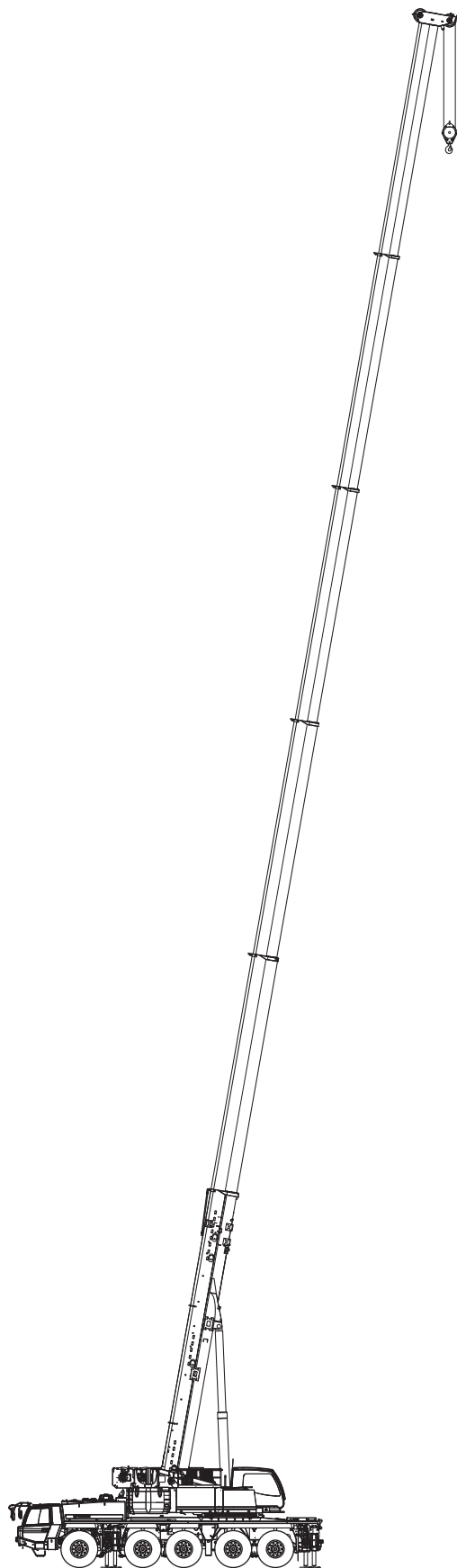

ブーム作業半径－揚程図

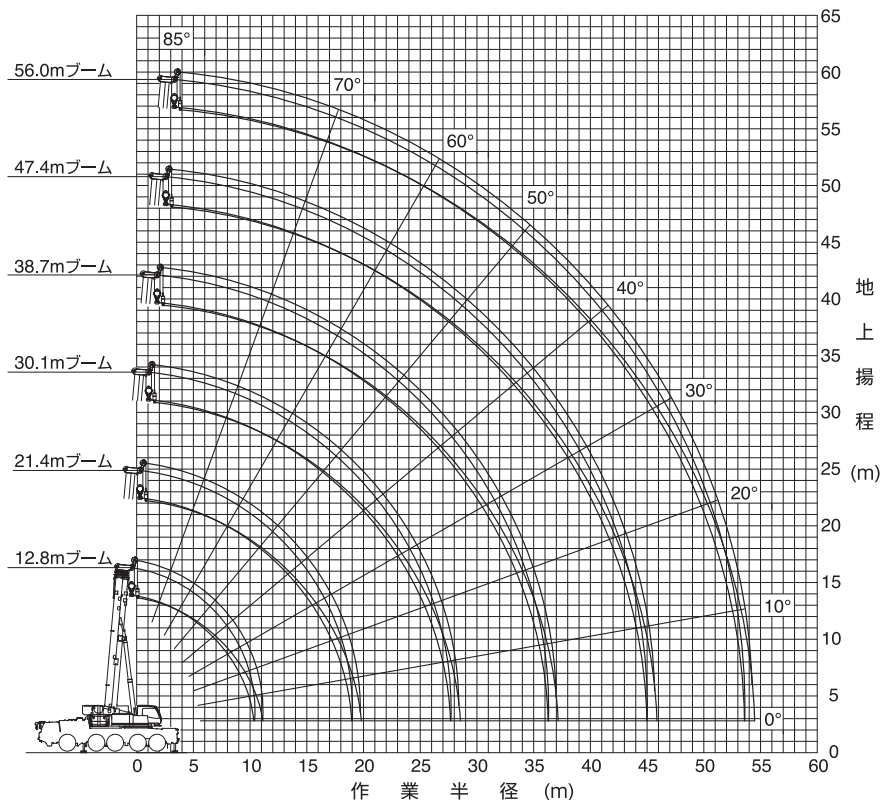

(注) 1. 上図はブームのたわみを含んでいません。
2. A、F性能の最大作業半径を図示しています。

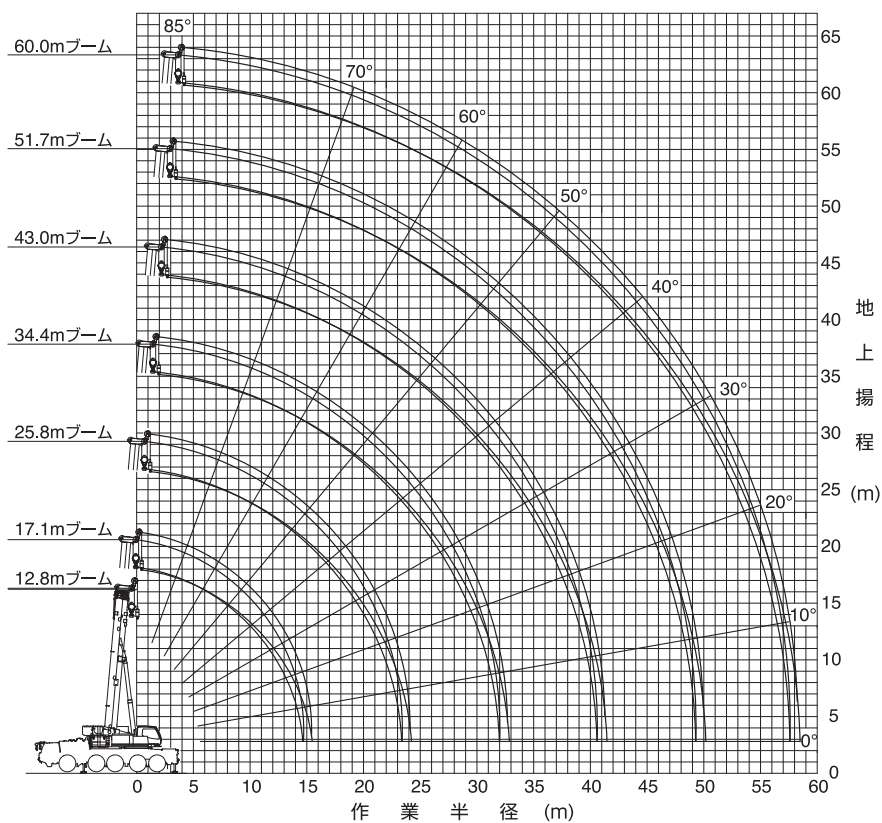

(注) 1. 上図はブームのたわみを含んでいません。
2. A、F性能の最大作業半径を図示しています。

ブーム定格総荷重表

■ 定格総荷重表注意事項

- ◆ 定格総荷重表の性能区分A～Tは、下表のとおりです。

アウトリガ張出幅	カウンタウエイト	40 t	28 t	25 t	15 t	6 t	0 t
7.5 m		A	B	C	D	E	K
6.2 m		F	G	H	I	J	K
5.0 m			L	M	N	O	P
4.1 m					Q	R	S
2.5 m							T

※同じ性能区分・ブーム長さでも、ブームの伸長状態によって定格総荷重が異なります。

※S性能は51.7mブーム、T性能は25.8mブームまでとなります

- ◆ 定格総荷重は、つり具質量とフック質量（90tフック：1,120kg、50tフック：600kg、22tフック：375kg、7.3tフック：300kg）を含んだ値を示します。
- ◆ 定格総荷重は、ブームのたわみを含んだ実際の作業半径に基づいています。
- ◆ 定格総荷重表中の標準巻掛本数より少ない本数で使用する場合、最大荷重の上限は下表のとおりです。

巻掛本数	13本	11本	8本	7本	6本	5本	4本	3本	1本
最大荷重	87.0t	75.0t	56.2t	49.6t	43.0t	36.2t	29.2t	21.9t	7.3t

- ◆ シングルトップ使用時の巻掛本数は1本（7.3tフック使用）で、定格総荷重はブームの定格総荷重からブームに取り付けられているフックの質量を差し引いた値とし、かつ上限は7.3tです。
- ◆ 定格総荷重は、アウトリガを水平堅土上に設置したときの値です。
- ◆ 定格総荷重表は、風による影響を含んでいません。瞬間最大風速が10m/s以上の風速では、クレーン作業を中止してください。
- ◆ 定格総荷重表中の太線より上側はクレーンの強度に、下側はクレーンの安定に基づいています。
- ◆ 「ピン無最大荷重」は、Bピン（ブーム固定ピン）を挿入していないときの定格総荷重の上限を示します。
- ◆ 「 $\theta(^{\circ})$ 」は、無負荷状態で可能なブーム起伏角度範囲を示します。

ブーム

■ 性能ブロック図

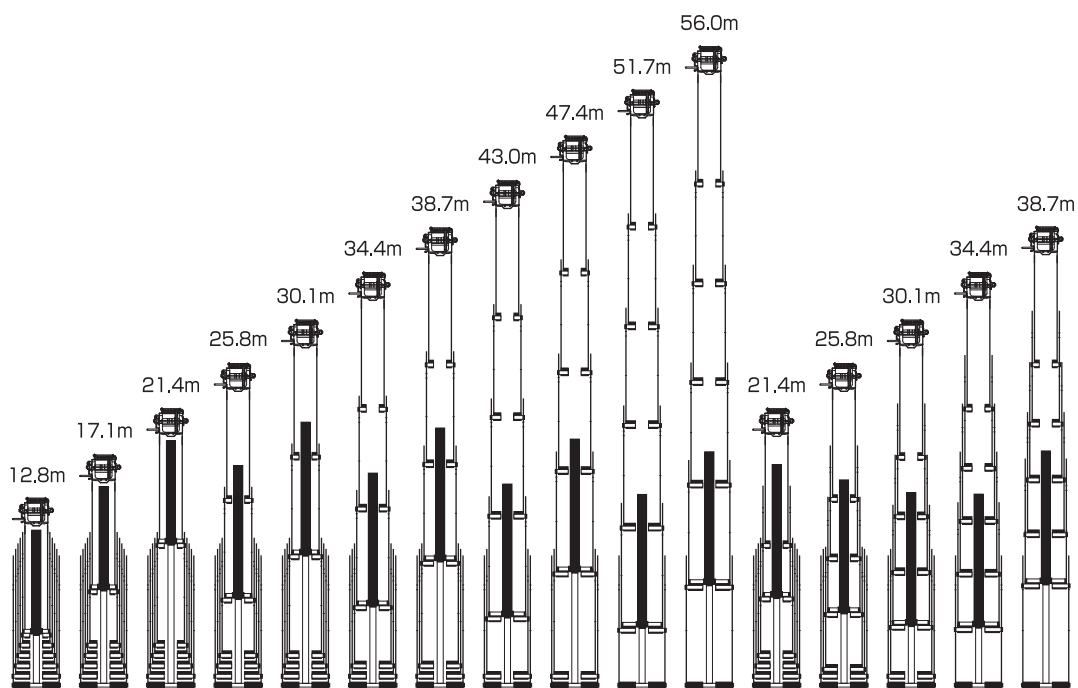

性能ブロック	1											2				
性能番号	1	2	3	4	5	6	7	8	9	10	11	12	13	14	15	16

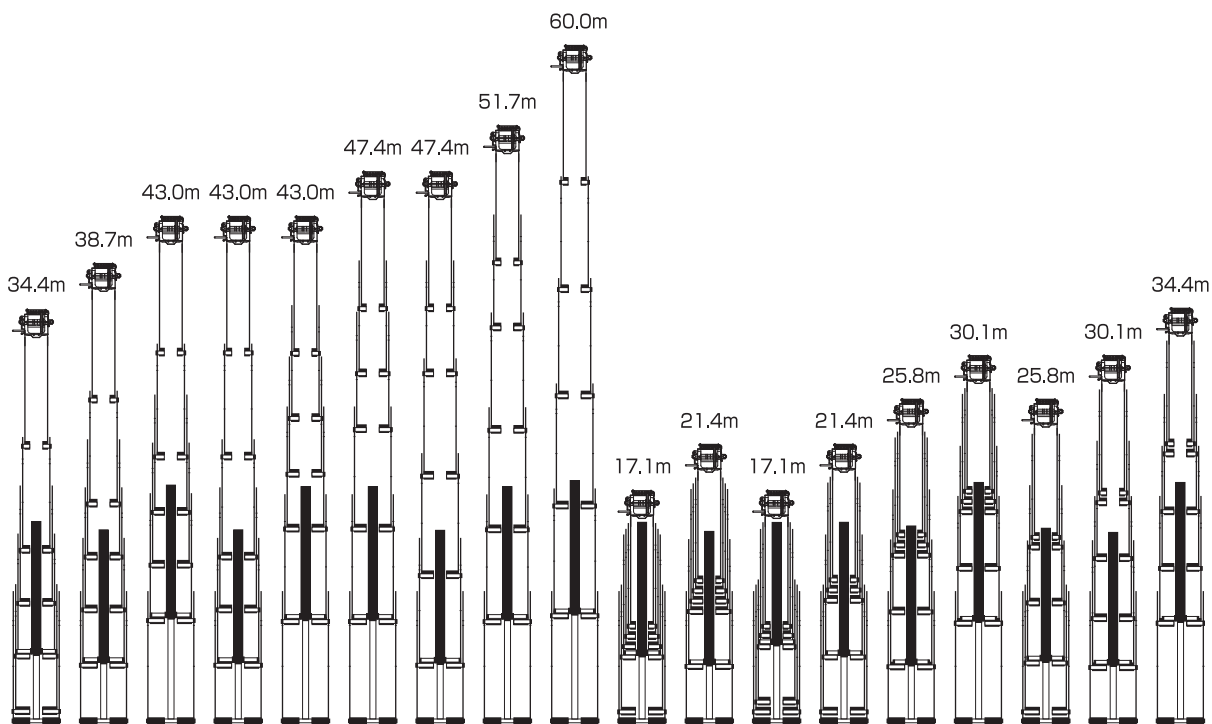

性能ブロック	3		4	5	6	7	8	9	10		11							
性能番号	17	18	19	20	21	22	23	24	25	26	27	28	29	30	31	32	33	34

[A性能]

ブーム

単位：t

Table with columns for boom length (性能ブロック), boom diameter (ブーム長さ), and lifting capacity (作業半径) for various configurations. Includes data for different boom lengths and radii.

注) カウンタウエイト40t、アウトリガ張出幅7.5m ※印はアタッチメント付き、ジブ無しでの値です。 ※※印は後方限定の値です。

[B性能]

ブーム

単位：t

Table with columns for boom length (性能ブロック), boom diameter (ブーム長さ), and lifting capacity (作業半径) for various configurations. Includes data for different boom lengths and radii.

注) カウンタウエイト28t、アウトリガ張出幅7.5m ※印はアタッチメント付き、ジブ無しでの値です。

【E性能】ブーム

単位: t

Table with columns for boom length (1-25m) and radius (1-8m). Rows include performance blocks, boom length/radius, and detailed weight data. Includes a note about counterweight and extension.

注) カウンタウエイト6t、アウトリガ張出幅7.5m ※印はアタッチメント付き、ジブ無しでの値です。

【F性能】ブーム

単位: t

Table with columns for boom length (1-25m) and radius (1-8m). Rows include performance blocks, boom length/radius, and detailed weight data. Includes a note about counterweight and extension.

注) カウンタウエイト40t、アウトリガ張出幅6.2m ※印はアタッチメント付き、ジブ無しでの値です。

[M性能] ブーム

単位: t

Table with columns for boom length (1-25m) and radius (1-8m). Rows include performance blocks, boom length/radius, maximum weight, hook weight, and standard hook count. Includes a section for extension ratios (伸長状態) and hook specifications.

注) カウンタウエイト25t、アウトリガ張出幅5.0m ※印はアタッチメント付き、ジブ無しでの値です。

[N性能] ブーム

単位: t

Table with columns for boom length (1-25m) and radius (1-8m). Rows include performance blocks, boom length/radius, maximum weight, hook weight, and standard hook count. Includes a section for extension ratios (伸長状態) and hook specifications.

注) カウンタウエイト15t、アウトリガ張出幅5.0m ※印はアタッチメント付き、ジブ無しでの値です。

【Q性能】ブーム

単位：t

Table with columns for boom length, diameter, and performance metrics (Q performance). Includes sub-sections for extension ratios and weight specifications.

注) カウンタウエイト15t、アウトリガ張出幅4.1m ※印はアタッチメント付き、ジブ無しでの値です。

【R性能】ブーム

単位：t

Table with columns for boom length, diameter, and performance metrics (R performance). Includes sub-sections for extension ratios and weight specifications.

注) カウンタウエイト6t、アウトリガ張出幅4.1m ※印はアタッチメント付き、ジブ無しでの値です。

ブーム

[S性能]

ブーム

単位：t

性能ブロック	1	9	10	1	9	10	2	1	10	11	2	1	11	2	3	1	2	3	1	5	3	4	1	6	7	1	7	1							
性能番号	1	26	28	2	27	29	12	3	30	32	13	4	31	33	14	5	34	15	17	6	16	18	7	21	19	20	8	22	23	9	24	10			
ブーム長さ(m)	※12.8	17.1			21.4			25.8			30.1			34.4			38.7			43.0			47.4			51.7									
作業半径(m)	84.5	77.7			78.2			78.9			45.5			78.0			79.1			46.6			34.1			25.8			17.1						
2.7	3.0	3.5	4.0	4.5	5.0	6.0	7.0	8.0	9.0	10.0	11.0	12.0	13.0	14.0	15.0	16.0	17.0	18.0	19.0	20.0	21.0	22.0	23.0	24.0	25.0	26.0	27.0	28.0	29.0	30.0	31.0	32.0	33.0	34.0	
31.9	32.7	34.4	34.5	30.4	31.9	33.3	27.8	30.0	32.1	32.3	32.2	26.5	29.9	30.7	26.6	26.5	28.8	29.5	25.1	27.1	27.4	20.5	26.6	23.1	20.7	19.0	21.4	18.6	15.7	16.6	14.3				
ピン無最大荷重	θ(°)	0-85	18-85	0-85	0-85	45-85	38-85	13-85	13-85	52-85	44-85	34-85	23-85	63-85	56-85	46-85	37-85	66-85	58-85	47-85	44-85	67-85	60-85	49-85	72-85	69-85	63-85	59-85	74-85	70-85	66-85	75-85	71-85		
伸長状態 (伸長割合%)																																			
伸縮ブーム1	0	0	0	0	46	0	0	0	46	0	0	0	92	46	0	0	92	46	0	0	92	46	0	92	92	46	0	92	46	0	92	46	0	92	46
伸縮ブーム2	0	46	0	0	46	46	0	0	46	46	0	0	46	46	46	0	46	46	46	0	46	46	0	46	46	46	46	46	46	46	46	46	46	46	46
伸縮ブーム3	0	0	46	0	0	46	0	0	46	46	46	0	46	46	46	0	46	46	46	46	46	46	46	46	46	46	46	46	46	46	46	46	46	46	46
伸縮ブーム4	0	0	0	0	0	46	0	0	46	46	46	0	46	46	46	46	46	46	46	46	46	46	46	46	46	46	46	46	46	46	46	46	46	46	46
伸縮ブーム5	0	0	0	46	0	0	46	92	0	0	46	92	0	0	46	92	0	46	92	46	92	46	92	46	92	46	92	46	92	46	92	46	92	46	92
標準フック	90t×2	90t	90t	50t	90t	90t	50t	50t	90t	90t	50t	50t	90t	90t	50t	50t	90t	90t	50t	50t	50t	50t	50t	50t	50t	50t	50t	50t	50t	50t	50t	50t	50t	50t	
フック質量	1120kg×2	1120kg	1120kg	600kg	1120kg	1120kg	600kg	600kg	1120kg	1120kg	600kg	600kg	1120kg	1120kg	600kg	600kg	1120kg	1120kg	600kg	600kg	600kg	600kg	600kg	600kg	600kg	600kg	600kg	600kg	600kg	600kg	600kg	600kg	600kg	600kg	
標準巻掛本数	24	13	13	7	13	13	7	5	11	8	7	5	8	8	6	4	7	6	5	4	5	4	3	4	4	3	3	3	3	3	3	3	3	3	

注) カウンタウエイトOt、アウトリガ張出幅4.1m ※印はアタッチメント付き、ジブ無しでの値です。

[T性能]

ブーム

単位：t

性能ブロック	1	9	10	1	9	10	2	1	10	11	2	1	
性能番号	1	26	28	2	27	29	12	3	30	32	13	4	
ブーム長さ(m)	※12.8	17.1			21.4			25.8					
作業半径(m)	41.2	32.8			33.2			38.5			34.1		
2.7	3.0	3.5	4.0	4.5	5.0	6.0	7.0	8.0	9.0	10.0	11.0	12.0	
31.9	32.7	34.4	34.5	30.4	31.9	33.3	27.8	30.0	32.1	32.3	32.2		
ピン無最大荷重	θ(°)	29-85	47-85	43-85	39-85	62-85	57-85	47-85	46-85	67-85	61-85	54-85	60-85
伸長状態 (伸長割合%)													
伸縮ブーム1	0	0	0	0	46	0	0	0	46	0	0	0	
伸縮ブーム2	0	46	0	0	46	46	0	0	46	46	0	0	
伸縮ブーム3	0	0	46	0	0	46	0	0	46	46	46	0	
伸縮ブーム4	0	0	0	0	0	0	46	0	0	46	46	46	
伸縮ブーム5	0	0	0	46	0	0	46	92	0	0	46	92	
標準フック	90t×2	90t	90t	50t	90t	90t	50t	50t	90t	90t	50t	50t	
フック質量	1120kg×2	1120kg	1120kg	600kg	1120kg	1120kg	600kg	600kg	1120kg	1120kg	600kg	600kg	
標準巻掛本数	24	13	13	7	13	13	7	5	11	8	7	5	

注) カウンタウエイトOt、アウトリガ張出幅2.5m ※印はアタッチメント付き、ジブ無しでの値です。

オールテレーンクレーン
ATF130G-5
フルオートラフティングジブ

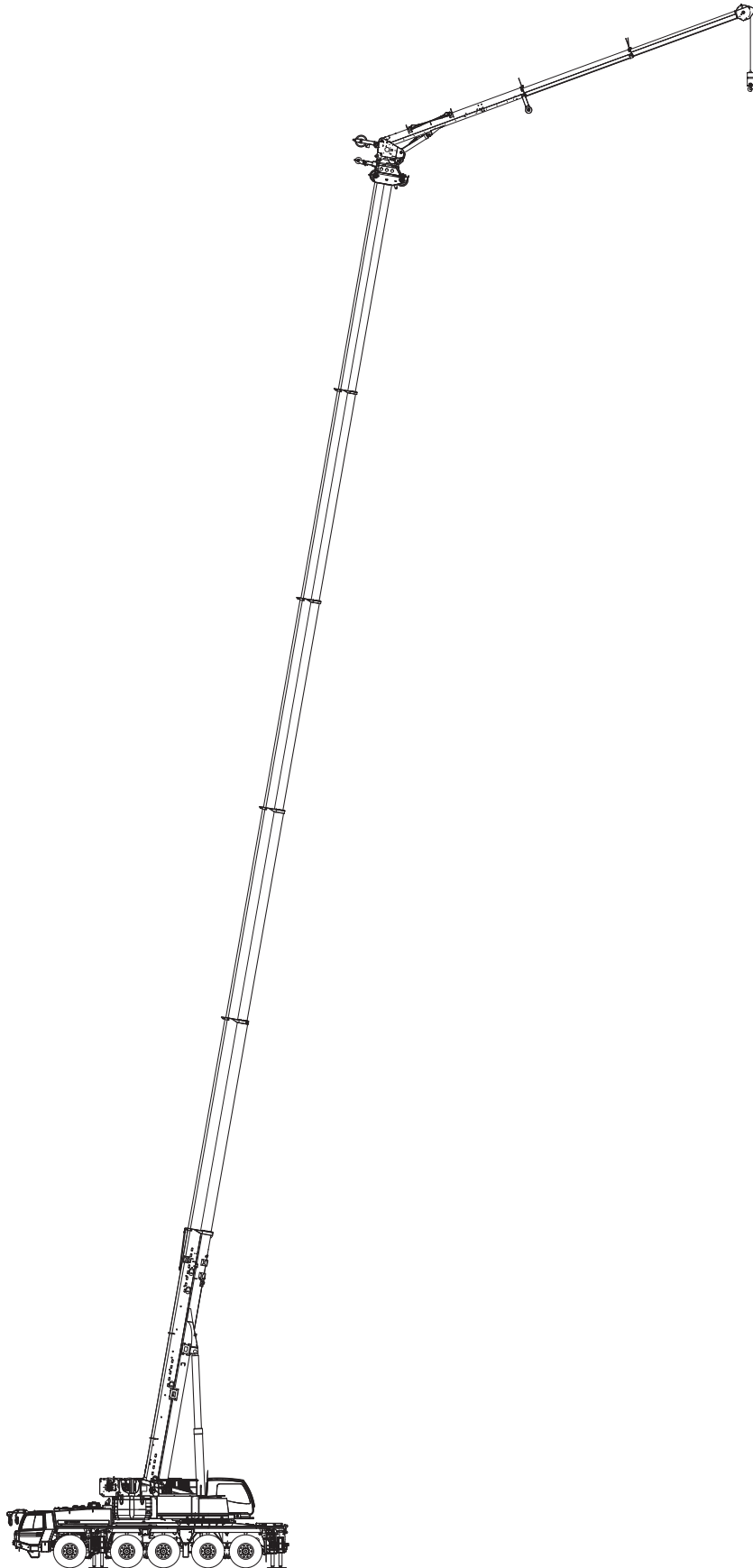

フルオートラフィングジブ

ブーム+フルオートラフィングジブ(FLJ)作業半径-揚程図

43.0mブーム+1.6m+フルオートラフィングジブ

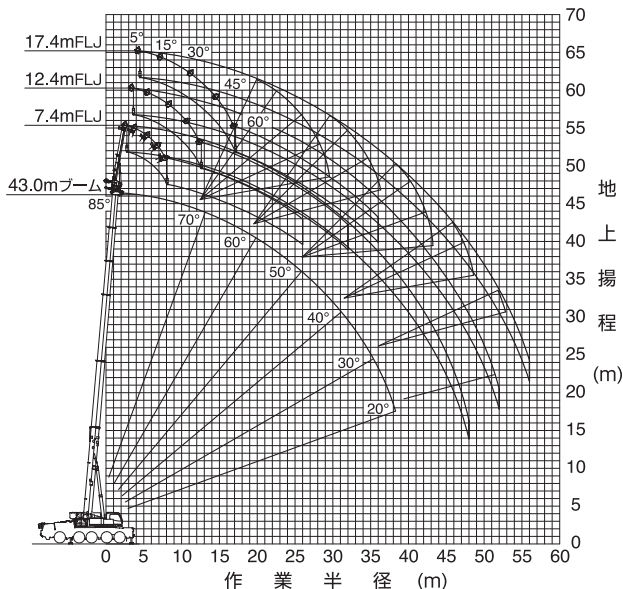

(注) 1. 上図はブームおよびジブのたわみを含んでいません。
2. A性能の最大作業半径を图示しています。

51.7mブーム+1.6m+フルオートラフィングジブ

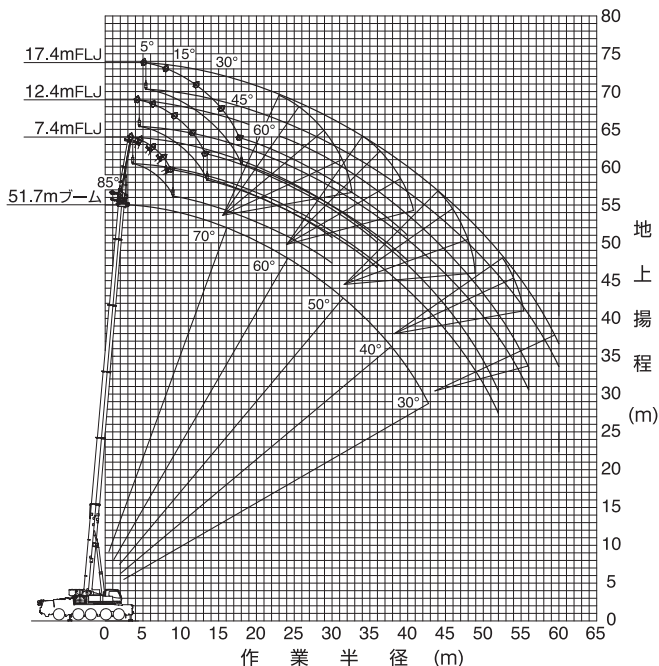

(注) 1. 上図はブームおよびジブのたわみを含んでいません。
2. A性能の最大作業半径を图示しています。

56.0mブーム+1.6m+フルオートラフィングジブ

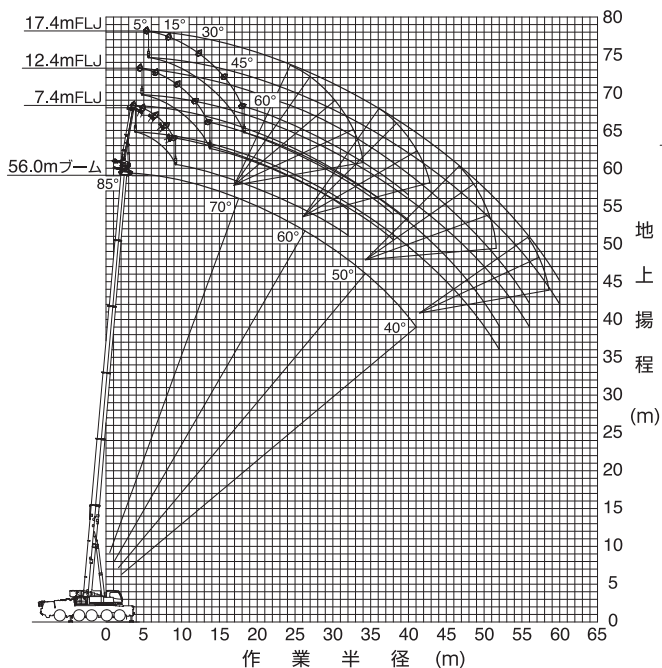

(注) 1. 上図はブームおよびジブのたわみを含んでいません。
2. A性能の最大作業半径を图示しています。

60.0mブーム+1.6m+フルオートラフィングジブ

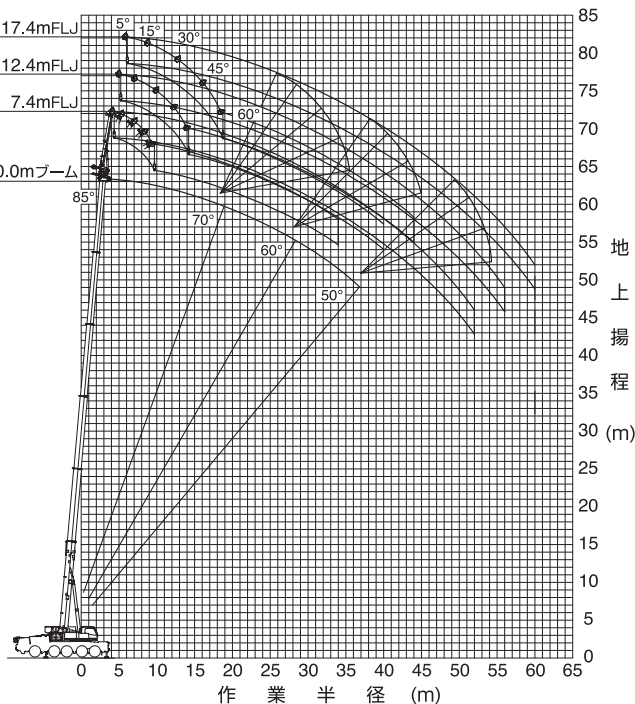

(注) 1. 上図はブームおよびジブのたわみを含んでいません。
2. A性能の最大作業半径を图示しています。

ブーム+フルオートラフィングジブ(FLJ)定格総荷重表

■ 定格総荷重表注意事項

◆ 定格総荷重表の性能区分A~I、L~Nは、下表のとおりです。

アウトリガ張出幅	カウンタウイト	40 t	28 t	25 t	15 t	6 t
7.5 m		A	B	C	D	E
6.2 m		F	G	H	I	
5.0 m			L	M	N	

- ◆ 定格総荷重は、つり具質量とフック質量（7.3tフック：300kg）を含んだ値を示します。
- ◆ 定格総荷重は、ブームとジブのたわみを含んだ実際の作業半径に基づいています。
- ◆ 各ブーム長さにおける各ブーム段の伸長状態（伸長割合％）は、下表のとおりです。

ブーム長さ	43.0 m	51.7 m	56.0 m	60.0 m
伸縮ブーム1	92	92	92	100
伸縮ブーム2	92	92	92	100
伸縮ブーム3	46	92	92	100
伸縮ブーム4	46	92	92	100
伸縮ブーム5	46	46	92	100

◆ 定格総荷重表中の標準巻掛本数よりも少ない本数で使用する場合、最大荷重の上限は下表のとおりです。

巻掛本数	1本
最大荷重	7.3t

- ◆ 定格総荷重は、アウトリガを水平堅土上に設置したときの値です。
- ◆ 定格総荷重表は、風による影響を含んでいません。瞬間最大風速が10m/s以上の風速では、クレーン作業を中止してください。
- ◆ 定格総荷重表中の太線より上側はクレーンの強度に、下側はクレーンの安定に基づいています。
- ◆ 「 $\theta(^{\circ})$ 」は、無負荷状態で可能なブーム起伏角度範囲を示します。

フルオートラフィングジブ

【A性能】

43.0mブーム+1.6m+フルオートラフィングジブ

単位:t

ジブ長さ 作業半径 (m)	7.4m					12.4m					17.4m				
	オフセット					オフセット					オフセット				
	5°	15°	30°	45°	60°	5°	15°	30°	45°	60°	5°	15°	30°	45°	60°
6.0	7.3														
7.0	7.3					4.3									
8.0	7.3	7.3				4.3					3.3				
9.0	7.3	7.3	7.3			4.3					3.3				
10.0	7.3	7.3	7.3	6.2		4.3	4.3				3.3				
11.0	7.3	7.3	7.3	6.1	4.5	4.3	4.3				3.3	3.3			
12.0	7.3	7.3	7.3	6.0	4.5	4.3	4.3	4.3			3.3	3.3			
14.0	7.3	7.3	7.3	5.8	4.4	4.3	4.3	4.2			3.3	3.2			
16.0	7.3	7.3	7.3	5.7	4.4	4.3	4.3	4.0	3.1	2.4	3.3	3.1	2.5		
18.0	7.3	7.3	6.9	5.5	4.3	4.3	4.3	3.8	3.0	2.4	3.3	2.9	2.4		
20.0	7.3	7.3	6.7	5.4	4.3	4.3	4.3	3.7	3.0	2.3	3.3	2.8	2.3		
22.0	7.3	7.3	6.4	5.3	4.2	4.3	4.3	3.6	2.9	2.3	3.1	2.6	2.2	1.8	
24.0	7.3	7.3	6.2	5.2	4.2	4.3	4.1	3.4	2.8	2.3	3.0	2.5	2.1	1.7	1.5
26.0	7.3	7.1	6.0	5.1	4.2	4.3	3.9	3.3	2.7	2.2	2.8	2.4	2.1	1.7	1.4
28.0	7.1	6.8	5.8	5.0		4.3	3.8	3.2	2.7	2.2	2.7	2.3	2.0	1.6	1.4
30.0	6.8	6.5	5.6	5.0		4.2	3.6	3.1	2.6	2.2	2.6	2.2	1.9	1.6	1.4
32.0	6.4	6.2	5.5	4.9		4.0	3.5	3.0	2.6	2.2	2.5	2.2	1.8	1.5	1.4
34.0	5.8	5.8	5.4	4.9		3.7	3.4	2.9	2.5		2.4	2.1	1.8	1.5	1.4
36.0	5.1	5.3	5.3	4.9		3.5	3.2	2.8	2.5		2.3	2.0	1.7	1.5	1.4
38.0	4.5	4.6	4.7			3.3	3.1	2.7	2.5		2.2	2.0	1.7	1.5	
40.0	3.9	4.0	4.1			3.2	3.0	2.7	2.5		2.1	1.9	1.6	1.4	
44.0	2.7	2.8				2.9	2.8	2.6			2.0	1.8	1.5	1.4	
48.0	1.7	1.7				2.5	2.6	2.5			1.8	1.7	1.5		
52.0						1.7	1.7				1.7	1.6	1.4		
56.0											1.5	1.5			
θ(°)	17~85	18~85	44~85	55~85	67~85	23~85	26~85	44~85	56~85	66~85	27~85	36~85	46~85	57~85	68~85
標準フック	7.3t														
フック質量	300kg														
標準巻掛本数	1														

注) カウンタウエイト 40t、アウトリガ張出幅 7.5m

【A性能】

51.7mブーム+1.6m+フルオートラフィングジブ

単位:t

ジブ長さ 作業半径 (m)	7.4m					12.4m					17.4m				
	オフセット					オフセット					オフセット				
	5°	15°	30°	45°	60°	5°	15°	30°	45°	60°	5°	15°	30°	45°	60°
8.0	7.3														
9.0	7.3	7.3													
10.0	7.3	7.3				4.3					3.2				
11.0	7.3	7.3	7.3			4.3					3.2				
12.0	7.3	7.3	7.3	6.2		4.3	4.3				3.2				
14.0	7.3	7.3	7.3	6.0	4.5	4.3	4.3				3.2	3.1			
16.0	7.3	7.3	7.3	5.8	4.4	4.3	4.3	3.9			3.2	3.0			
18.0	7.3	7.3	7.0	5.7	4.3	4.3	4.3	3.8	3.1		3.2	2.8	2.3		
20.0	7.1	6.9	6.6	5.6	4.3	4.3	4.3	3.6	3.0	2.3	3.1	2.7	2.3		
22.0	6.7	6.5	6.3	5.4	4.3	4.3	4.2	3.5	2.9	2.3	3.0	2.6	2.2		
24.0	6.3	6.2	6.0	5.3	4.2	4.3	4.1	3.4	2.9	2.3	2.9	2.5	2.1	1.8	
26.0	6.0	5.8	5.7	5.2	4.2	4.3	3.9	3.3	2.8	2.3	2.8	2.4	2.0	1.7	1.4
28.0	5.6	5.5	5.4	5.2	4.2	4.3	3.8	3.2	2.7	2.2	2.7	2.3	2.0	1.7	1.4
30.0	5.3	5.2	5.1	5.0	4.2	4.2	3.6	3.1	2.7	2.2	2.6	2.3	1.9	1.6	1.4
32.0	5.0	4.9	4.8	4.7		4.0	3.5	3.0	2.6	2.2	2.5	2.2	1.9	1.6	1.4
34.0	4.7	4.6	4.5	4.5		3.9	3.4	3.0	2.6	2.2	2.4	2.1	1.8	1.6	1.4
36.0	4.4	4.4	4.3	4.3		3.7	3.3	2.9	2.6	2.2	2.3	2.0	1.8	1.5	1.4
38.0	4.0	4.1	4.1	4.1		3.6	3.2	2.8	2.5		2.2	2.0	1.7	1.5	1.4
40.0	3.6	3.7	3.8	3.8		3.5	3.1	2.8	2.5		2.2	1.9	1.7	1.5	1.4
44.0	2.9	3.0	3.0			3.3	3.0	2.7	2.5		2.0	1.8	1.6	1.4	
48.0	1.9	2.0	2.1			2.6	2.7	2.6			1.9	1.7	1.6	1.4	
52.0	1.1	1.2				1.8	1.9	2.0			1.8	1.7	1.5	1.4	
56.0						1.1	1.1	1.2			1.6	1.6	1.5		
60.0											1.0	1.1	1.2		
θ(°)	31~85	32~85	42~85	58~85	69~85	34~85	38~85	44~85	62~85	67~85	38~85	45~85	46~85	57~85	66~85
標準フック	7.3t														
フック質量	300kg														
標準巻掛本数	1														

注) カウンタウエイト 40t、アウトリガ張出幅 7.5m

[A性能]

56.0mブーム+1.6m+フルオートラフィングジブ

単位:t

ジブ長さ 作業半径 (m)	7.4m					12.4m					17.4m				
	オフセット					オフセット					オフセット				
	5°	15°	30°	45°	60°	5°	15°	30°	45°	60°	5°	15°	30°	45°	60°
9.0	6.3														
10.0	6.3	6.3													
11.0	6.3	6.3				4.3									
12.0	6.3	6.3	6.3			4.3					2.9				
14.0	6.3	6.3	6.3	6.0		4.3	4.3				2.9				
16.0	6.3	6.3	6.1	5.9	4.4	4.3	4.3	3.8			2.9	2.8			
18.0	6.3	6.0	5.7	5.6	4.4	4.3	4.3	3.7	3.1		2.9	2.8			
20.0	5.9	5.7	5.4	5.3	4.3	4.3	4.3	3.5	3.1	2.3	2.9	2.7	2.2		
22.0	5.6	5.4	5.2	5.1	4.3	4.3	4.1	3.4	3.0	2.3	2.9	2.6	2.1		
24.0	5.3	5.1	4.9	4.8	4.2	4.3	4.0	3.3	2.9	2.3	2.8	2.5	2.1	1.8	
26.0	5.0	4.9	4.7	4.6	4.2	4.3	3.8	3.2	2.8	2.3	2.7	2.4	2.0	1.7	1.4
28.0	4.7	4.6	4.5	4.4	4.2	4.1	3.7	3.1	2.8	2.2	2.7	2.3	2.0	1.7	1.4
30.0	4.5	4.4	4.3	4.3	4.2	4.0	3.6	3.0	2.7	2.2	2.6	2.2	1.9	1.6	1.4
32.0	4.3	4.2	4.1	4.1	4.1	3.8	3.4	3.0	2.7	2.2	2.5	2.2	1.9	1.6	1.4
34.0	4.1	4.0	3.9	3.9		3.6	3.3	2.9	2.6	2.2	2.4	2.1	1.8	1.6	1.4
36.0	3.9	3.8	3.7	3.7		3.5	3.2	2.8	2.6	2.2	2.3	2.0	1.8	1.5	1.4
38.0	3.7	3.7	3.6	3.6		3.3	3.1	2.8	2.6	2.2	2.2	2.0	1.7	1.5	1.4
40.0	3.5	3.4	3.4	3.4		3.2	3.1	2.7	2.5		2.2	1.9	1.7	1.5	1.4
44.0	2.8	2.9	3.0	3.0		2.9	2.9	2.6	2.5		2.0	1.8	1.6	1.4	
48.0	2.2	2.3	2.4			2.6	2.6	2.5	2.5		1.9	1.7	1.5	1.4	
52.0	1.4	1.4	1.5			1.9	2.1	2.2			1.8	1.6	1.5	1.4	
56.0						1.2	1.4	1.5			1.7	1.6	1.5		
60.0											1.1	1.3	1.4		
64.0													0.8		
θ(°)	39~85	41~85	43~85	56~85	70~85	41~85	45~85	50~85	60~85	67~85	44~85	54~85	48~85	63~85	69~85
標準フック	7.3t														
フック質量	300kg														
標準巻掛本数	1														

注) カウンタウエイト 40t、アウトリガ張出幅 7.5m

[A性能]

60.0mブーム+1.6m+フルオートラフィングジブ

単位:t

ジブ長さ 作業半径 (m)	7.4m					12.4m					17.4m				
	オフセット					オフセット					オフセット				
	5°	15°	30°	45°	60°	5°	15°	30°	45°	60°	5°	15°	30°	45°	60°
9.0	5.3														
10.0	5.3														
11.0	5.3	5.3													
12.0	5.3	5.3				4.1									
14.0	5.3	5.3	5.3			4.1					2.8				
16.0	5.3	5.3	5.3	5.3		4.1	4.1				2.8	2.7			
18.0	5.3	5.3	5.3	5.1	4.4	4.1	4.1	3.6			2.8	2.6			
20.0	5.3	5.2	5.0	4.9	4.3	4.1	4.1	3.5	3.1		2.7	2.6	2.2		
22.0	5.1	4.9	4.7	4.6	4.3	4.1	4.0	3.4	3.0	2.3	2.7	2.5	2.1		
24.0	4.8	4.7	4.5	4.4	4.3	4.1	3.9	3.3	2.9	2.3	2.7	2.4	2.1		
26.0	4.5	4.4	4.3	4.2	4.2	4.0	3.8	3.2	2.9	2.3	2.6	2.4	2.0	1.7	
28.0	4.3	4.2	4.1	4.1	4.1	3.8	3.6	3.1	2.8	2.2	2.6	2.3	1.9	1.7	1.4
30.0	4.1	4.0	3.9	3.9	3.9	3.6	3.5	3.0	2.8	2.2	2.5	2.2	1.9	1.7	1.4
32.0	3.9	3.8	3.7	3.7	3.7	3.5	3.4	2.9	2.7	2.2	2.5	2.1	1.8	1.6	1.4
34.0	3.7	3.6	3.6	3.5	3.5	3.3	3.2	2.9	2.7	2.2	2.4	2.1	1.8	1.6	1.4
36.0	3.5	3.5	3.4	3.4		3.2	3.1	2.8	2.6	2.2	2.3	2.0	1.7	1.6	1.4
38.0	3.4	3.3	3.2	3.2		3.0	3.0	2.7	2.6	2.2	2.2	2.0	1.7	1.5	1.4
40.0	3.2	3.1	3.1	3.1		2.9	2.8	2.7	2.5	2.2	2.2	1.9	1.7	1.5	1.4
44.0	2.6	2.6	2.7	2.7		2.5	2.4	2.4	2.4		2.0	1.8	1.6	1.5	1.4
48.0	2.0	2.0	2.1	2.1		2.2	2.2	2.1	2.2		1.9	1.7	1.5	1.4	
52.0	1.3	1.4	1.5			1.8	1.9	1.9	1.9		1.8	1.6	1.5	1.4	
56.0						1.2	1.3	1.4			1.6	1.6	1.4	1.4	
60.0								0.8			1.0	1.2	1.4		
64.0													0.8		
θ(°)	44~85	46~85	47~85	54~85	69~85	46~85	50~85	50~85	59~85	68~85	50~85	56~85	54~85	60~85	67~85
標準フック	7.3t														
フック質量	300kg														
標準巻掛本数	1														

注) カウンタウエイト 40t、アウトリガ張出幅 7.5m

フルオートラフィングジブ

【B性能】

43.0mブーム+1.6m+フルオートラフィングジブ

単位:t

ジブ長さ 作業半径 (m)	7.4m オフセット					12.4m オフセット					17.4m オフセット				
	5°	15°	30°	45°	60°	5°	15°	30°	45°	60°	5°	15°	30°	45°	60°
6.0	7.3														
7.0	7.3					4.3									
8.0	7.3	7.3				4.3					3.3				
9.0	7.3	7.3	7.3			4.3					3.3				
10.0	7.3	7.3	7.3	6.2		4.3	4.3				3.3				
11.0	7.3	7.3	7.3	6.1	4.5	4.3	4.3				3.3	3.3			
12.0	7.3	7.3	7.3	6.0	4.5	4.3	4.3	4.3			3.3	3.3			
14.0	7.3	7.3	7.3	5.8	4.4	4.3	4.3	4.2			3.3	3.2			
16.0	7.3	7.3	7.3	5.7	4.4	4.3	4.3	4.0	3.1	2.4	3.3	3.1	2.5		
18.0	7.3	7.3	6.9	5.5	4.3	4.3	4.3	3.8	3.0	2.4	3.3	2.9	2.4		
20.0	7.3	7.3	6.7	5.4	4.3	4.3	4.3	3.7	3.0	2.3	3.3	2.8	2.3		
22.0	7.3	7.3	6.4	5.3	4.2	4.3	4.3	3.6	2.9	2.3	3.1	2.6	2.2	1.8	
24.0	7.3	7.3	6.2	5.2	4.2	4.3	4.1	3.4	2.8	2.3	3.0	2.5	2.1	1.7	1.5
26.0	7.3	7.1	6.0	5.1	4.2	4.3	3.9	3.3	2.7	2.2	2.8	2.4	2.1	1.7	1.4
28.0	6.4	6.6	5.8	5.0		4.3	3.8	3.2	2.7	2.2	2.7	2.3	2.0	1.6	1.4
30.0	5.5	5.6	5.6	5.0		4.2	3.6	3.1	2.6	2.2	2.6	2.2	1.9	1.6	1.4
32.0	4.6	4.8	5.0	4.9		4.0	3.5	3.0	2.6	2.2	2.5	2.2	1.8	1.5	1.4
34.0	3.8	3.9	4.2	4.2		3.7	3.4	2.9	2.5		2.4	2.1	1.8	1.5	1.4
36.0	3.0	3.2	3.4	3.4		3.5	3.2	2.8	2.5		2.3	2.0	1.7	1.5	1.4
38.0	2.4	2.5	2.6			3.2	3.1	2.7	2.5		2.2	2.0	1.7	1.5	
40.0	1.8	1.9	2.0			2.6	2.8	2.7	2.5		2.1	1.9	1.6	1.4	
44.0	0.8	0.9				1.6	1.8	1.9			2.0	1.8	1.5	1.4	
48.0						0.8	0.9	1.0			1.4	1.6	1.5		
52.0												0.9	1.0		
θ(°)	30~85	31~85	42~85	53~85	67~85	32~85	35~85	41~85	56~85	66~85	42~85	42~85	45~85	57~85	68~85
標準フック											7.3t				
フック質量											300kg				
標準巻掛本数											1				

注) カウンタウエイト 28t、アウトリガ張出幅 7.5m

【B性能】

51.7mブーム+1.6m+フルオートラフィングジブ

単位:t

ジブ長さ 作業半径 (m)	7.4m オフセット					12.4m オフセット					17.4m オフセット				
	5°	15°	30°	45°	60°	5°	15°	30°	45°	60°	5°	15°	30°	45°	60°
8.0	7.3														
9.0	7.3	7.3													
10.0	7.3	7.3				4.3					3.2				
11.0	7.3	7.3	7.3			4.3					3.2				
12.0	7.3	7.3	7.3	6.2		4.3	4.3				3.2				
14.0	7.3	7.3	7.3	6.0	4.5	4.3	4.3				3.2	3.1			
16.0	7.3	7.3	7.3	5.8	4.4	4.3	4.3	3.9			3.2	3.0			
18.0	7.3	7.3	7.0	5.7	4.3	4.3	4.3	3.8	3.1		3.2	2.8	2.3		
20.0	7.1	6.9	6.6	5.6	4.3	4.3	4.3	3.6	3.0	2.3	3.1	2.7	2.3		
22.0	6.7	6.5	6.3	5.4	4.3	4.3	4.2	3.5	2.9	2.3	3.0	2.6	2.2		
24.0	6.3	6.2	6.0	5.3	4.2	4.3	4.1	3.4	2.9	2.3	2.9	2.5	2.1	1.8	
26.0	6.0	5.8	5.7	5.2	4.2	4.3	3.9	3.3	2.8	2.3	2.8	2.4	2.0	1.7	1.4
28.0	5.6	5.5	5.4	5.2	4.2	4.3	3.8	3.2	2.7	2.2	2.7	2.3	2.0	1.7	1.4
30.0	5.3	5.2	5.1	5.0	4.2	4.2	3.6	3.1	2.7	2.2	2.6	2.3	1.9	1.6	1.4
32.0	4.8	4.9	4.8	4.7		4.0	3.5	3.0	2.6	2.2	2.5	2.2	1.9	1.6	1.4
34.0	4.0	4.2	4.4	4.5		3.9	3.4	3.0	2.6	2.2	2.4	2.1	1.8	1.6	1.4
36.0	3.2	3.4	3.6	3.8		3.7	3.3	2.9	2.6	2.2	2.3	2.0	1.8	1.5	1.4
38.0	2.6	2.8	2.9	3.0		3.3	3.2	2.8	2.5		2.2	2.0	1.7	1.5	1.4
40.0	2.0	2.2	2.3	2.4		2.7	3.0	2.8	2.5		2.2	1.9	1.7	1.5	1.4
44.0	1.0	1.1	1.3			1.7	1.9	2.2	2.3		2.0	1.8	1.6	1.4	
48.0						0.9	1.0	1.2			1.4	1.7	1.6	1.4	
52.0												1.0	1.2	1.3	
θ(°)	44~85	46~85	47~85	56~85	69~85	45~85	49~85	54~85	61~85	67~85	53~85	54~85	55~85	56~85	66~85
標準フック											7.3t				
フック質量											300kg				
標準巻掛本数											1				

注) カウンタウエイト 28t、アウトリガ張出幅 7.5m

【B性能】

56.0mブーム+1.6m+フルオートラフィングジブ

単位:t

ジブ長さ 作業半径 (m)	7.4m					12.4m					17.4m				
	オフセット					オフセット					オフセット				
	5°	15°	30°	45°	60°	5°	15°	30°	45°	60°	5°	15°	30°	45°	60°
9.0	6.3														
10.0	6.3	6.3													
11.0	6.3	6.3				4.3									
12.0	6.3	6.3	6.3			4.3					2.9				
14.0	6.3	6.3	6.3	6.0		4.3	4.3				2.9				
16.0	6.3	6.3	6.1	5.9	4.4	4.3	4.3	3.8			2.9	2.8			
18.0	6.3	6.0	5.7	5.6	4.4	4.3	4.3	3.7	3.1		2.9	2.8			
20.0	5.9	5.7	5.4	5.3	4.3	4.3	4.3	3.5	3.1	2.3	2.9	2.7	2.2		
22.0	5.6	5.4	5.2	5.1	4.3	4.3	4.1	3.4	3.0	2.3	2.9	2.6	2.1		
24.0	5.3	5.1	4.9	4.8	4.2	4.3	4.0	3.3	2.9	2.3	2.8	2.5	2.1	1.8	
26.0	5.0	4.9	4.7	4.6	4.2	4.3	3.8	3.2	2.8	2.3	2.7	2.4	2.0	1.7	1.4
28.0	4.7	4.6	4.5	4.4	4.2	4.1	3.7	3.1	2.8	2.2	2.7	2.3	2.0	1.7	1.4
30.0	4.5	4.4	4.3	4.3	4.2	4.0	3.6	3.0	2.7	2.2	2.6	2.2	1.9	1.6	1.4
32.0	4.3	4.2	4.1	4.1	4.1	3.8	3.4	3.0	2.7	2.2	2.5	2.2	1.9	1.6	1.4
34.0	4.1	4.0	3.9	3.9		3.6	3.3	2.9	2.6	2.2	2.4	2.1	1.8	1.6	1.4
36.0	3.5	3.7	3.7	3.7		3.5	3.2	2.8	2.6	2.2	2.3	2.0	1.8	1.5	1.4
38.0	2.9	3.0	3.2	3.3		3.3	3.1	2.8	2.6	2.2	2.2	2.0	1.7	1.5	1.4
40.0	2.3	2.4	2.6	2.7		2.9	3.1	2.7	2.5		2.2	1.9	1.7	1.5	1.4
44.0	1.3	1.4	1.5	1.6		1.9	2.1	2.4	2.5		2.0	1.8	1.6	1.4	
48.0						1.1	1.3	1.5	1.6		1.6	1.7	1.5	1.4	
52.0											0.9	1.1	1.4	1.4	
θ(°)	49~85	51~85	53~85	54~85	70~85	50~85	54~85	58~85	58~85	67~85	52~85	60~85	62~85	63~85	69~85
標準フック	7.3t														
フック質量	300kg														
標準巻掛本数	1														

注) カウンタウエイト 28t、アウトリガ張出幅 7.5m

【B性能】

60.0mブーム+1.6m+フルオートラフィングジブ

単位:t

ジブ長さ 作業半径 (m)	7.4m					12.4m					17.4m				
	オフセット					オフセット					オフセット				
	5°	15°	30°	45°	60°	5°	15°	30°	45°	60°	5°	15°	30°	45°	60°
9.0	5.3														
10.0	5.3														
11.0	5.3	5.3													
12.0	5.3	5.3				4.1									
14.0	5.3	5.3	5.3			4.1					2.8				
16.0	5.3	5.3	5.3	5.3		4.1	4.1				2.8	2.7			
18.0	5.3	5.3	5.3	5.1	4.4	4.1	4.1	3.6			2.8	2.6			
20.0	5.3	5.2	5.0	4.9	4.3	4.1	4.1	3.5	3.1		2.7	2.6	2.2		
22.0	5.1	4.9	4.7	4.6	4.3	4.1	4.0	3.4	3.0	2.3	2.7	2.5	2.1		
24.0	4.8	4.7	4.5	4.4	4.3	4.1	3.9	3.3	2.9	2.3	2.7	2.4	2.1		
26.0	4.5	4.4	4.3	4.2	4.2	4.0	3.8	3.2	2.9	2.3	2.6	2.4	2.0	1.7	
28.0	4.3	4.2	4.1	4.1	4.1	3.8	3.6	3.1	2.8	2.2	2.6	2.3	1.9	1.7	1.4
30.0	4.1	4.0	3.9	3.9	3.9	3.6	3.5	3.0	2.8	2.2	2.5	2.2	1.9	1.7	1.4
32.0	3.9	3.8	3.7	3.7	3.7	3.5	3.4	2.9	2.7	2.2	2.5	2.1	1.8	1.6	1.4
34.0	3.7	3.6	3.6	3.5	3.5	3.3	3.2	2.9	2.7	2.2	2.4	2.1	1.8	1.6	1.4
36.0	3.4	3.5	3.4	3.4		3.2	3.1	2.8	2.6	2.2	2.3	2.0	1.7	1.6	1.4
38.0	2.8	3.0	3.2	3.2		3.0	3.0	2.7	2.6	2.2	2.2	2.0	1.7	1.5	1.4
40.0	2.2	2.4	2.6	2.7		2.8	2.8	2.7	2.5	2.2	2.2	1.9	1.7	1.5	1.4
44.0	1.2	1.4	1.5	1.6		1.8	2.1	2.3	2.4		2.0	1.8	1.6	1.5	1.4
48.0						1.0	1.2	1.4	1.5		1.5	1.7	1.5	1.4	
52.0											0.8	1.0	1.3	1.4	
56.0														0.8	
θ(°)	53~85	55~85	56~85	57~85	69~85	54~85	57~85	62~85	62~85	68~85	57~85	62~85	65~85	58~85	67~85
標準フック	7.3t														
フック質量	300kg														
標準巻掛本数	1														

注) カウンタウエイト28t、アウトリガ張出幅 7.5m

フルオートラフィングジブ

【C性能】

43.0mブーム+1.6m+フルオートラフィングジブ

単位:t

ジブ長さ 作業半径 (m)	7.4m					12.4m					17.4m				
	オフセット					オフセット					オフセット				
	5°	15°	30°	45°	60°	5°	15°	30°	45°	60°	5°	15°	30°	45°	60°
6.0	7.3														
7.0	7.3					4.3									
8.0	7.3	7.3				4.3					3.3				
9.0	7.3	7.3	7.3			4.3					3.3				
10.0	7.3	7.3	7.3	6.2		4.3	4.3				3.3				
11.0	7.3	7.3	7.3	6.1	4.5	4.3	4.3				3.3	3.3			
12.0	7.3	7.3	7.3	6.0	4.5	4.3	4.3	4.3			3.3	3.3			
14.0	7.3	7.3	7.3	5.8	4.4	4.3	4.3	4.2			3.3	3.2			
16.0	7.3	7.3	7.3	5.7	4.4	4.3	4.3	4.0	3.1	2.4	3.3	3.1	2.5		
18.0	7.3	7.3	6.9	5.5	4.3	4.3	4.3	3.8	3.0	2.4	3.3	2.9	2.4		
20.0	7.3	7.3	6.7	5.4	4.3	4.3	4.3	3.7	3.0	2.3	3.3	2.8	2.3		
22.0	7.3	7.3	6.4	5.3	4.2	4.3	4.3	3.6	2.9	2.3	3.1	2.6	2.2	1.8	
24.0	7.3	7.3	6.2	5.2	4.2	4.3	4.1	3.4	2.8	2.3	3.0	2.5	2.1	1.7	1.5
26.0	6.8	7.1	6.0	5.1	4.2	4.3	3.9	3.3	2.7	2.2	2.8	2.4	2.1	1.7	1.4
28.0	5.7	5.9	5.8	5.0		4.3	3.8	3.2	2.7	2.2	2.7	2.3	2.0	1.6	1.4
30.0	4.7	4.9	5.1	5.0		4.2	3.6	3.1	2.6	2.2	2.6	2.2	1.9	1.6	1.4
32.0	3.8	4.0	4.2	4.3		4.0	3.5	3.0	2.6	2.2	2.5	2.2	1.8	1.5	1.4
34.0	3.1	3.2	3.4	3.5		3.7	3.4	2.9	2.5		2.4	2.1	1.8	1.5	1.4
36.0	2.4	2.6	2.7	2.8		3.1	3.2	2.8	2.5		2.3	2.0	1.7	1.5	1.4
38.0	1.8	2.0	2.1			2.6	2.8	2.7	2.5		2.2	2.0	1.7	1.5	
40.0	1.3	1.4	1.5			2.1	2.3	2.5	2.5		2.1	1.9	1.6	1.4	
44.0						1.1	1.3	1.5			1.8	1.8	1.5	1.4	
48.0											1.0	1.2	1.4		
θ(°)	38~85	40~85	42~85	53~85	67~85	40~85	43~85	49~85	56~85	66~85	41~85	48~85	52~85	57~85	68~85
標準フック	7.3t														
フック質量	300kg														
標準巻掛本数	1														

注) カウンタウエイト 25t、アウトリガ張出幅 7.5m

【C性能】

51.7mブーム+1.6m+フルオートラフィングジブ

単位:t

ジブ長さ 作業半径 (m)	7.4m					12.4m					17.4m				
	オフセット					オフセット					オフセット				
	5°	15°	30°	45°	60°	5°	15°	30°	45°	60°	5°	15°	30°	45°	60°
8.0	7.3														
9.0	7.3	7.3													
10.0	7.3	7.3				4.3					3.2				
11.0	7.3	7.3	7.3			4.3					3.2				
12.0	7.3	7.3	7.3	6.2		4.3	4.3				3.2				
14.0	7.3	7.3	7.3	6.0	4.5	4.3	4.3				3.2	3.1			
16.0	7.3	7.3	7.3	5.8	4.4	4.3	4.3	3.9			3.2	3.0			
18.0	7.3	7.3	7.0	5.7	4.3	4.3	4.3	3.8	3.1		3.2	2.8	2.3		
20.0	7.1	6.9	6.6	5.6	4.3	4.3	4.3	3.6	3.0	2.3	3.1	2.7	2.3		
22.0	6.7	6.5	6.3	5.4	4.3	4.3	4.2	3.5	2.9	2.3	3.0	2.6	2.2		
24.0	6.3	6.2	6.0	5.3	4.2	4.3	4.1	3.4	2.9	2.3	2.9	2.5	2.1	1.8	
26.0	6.0	5.8	5.7	5.2	4.2	4.3	3.9	3.3	2.8	2.3	2.8	2.4	2.0	1.7	1.4
28.0	5.6	5.5	5.4	5.2	4.2	4.3	3.8	3.2	2.7	2.2	2.7	2.3	2.0	1.7	1.4
30.0	4.8	5.1	5.1	5.0	4.2	4.2	3.6	3.1	2.7	2.2	2.6	2.3	1.9	1.6	1.4
32.0	4.0	4.2	4.4	4.6		4.0	3.5	3.0	2.6	2.2	2.5	2.2	1.9	1.6	1.4
34.0	3.3	3.4	3.6	3.8		3.9	3.4	3.0	2.6	2.2	2.4	2.1	1.8	1.6	1.4
36.0	2.6	2.8	3.0	3.1		3.2	3.3	2.9	2.6	2.2	2.3	2.0	1.8	1.5	1.4
38.0	2.0	2.2	2.4	2.5		2.7	2.9	2.8	2.5		2.2	2.0	1.7	1.5	1.4
40.0	1.5	1.6	1.8	1.9		2.2	2.4	2.6	2.5		2.2	1.9	1.7	1.5	1.4
44.0			0.8			1.2	1.4	1.7	1.8		1.8	1.8	1.6	1.4	
48.0								0.8			1.0	1.3	1.6	1.4	
52.0													0.8	0.9	
θ(°)	50~85	51~85	47~85	55~85	65~85	50~85	54~85	53~85	60~85	67~85	52~85	58~85	55~85	56~85	66~85
標準フック	7.3t														
フック質量	300kg														
標準巻掛本数	1														

注) カウンタウエイト 25t、アウトリガ張出幅 7.5m

【C性能】

56.0mブーム+1.6m+フルオートラフィングジブ

単位:t

ジブ長さ 作業半径 (m)	7.4m オフセット					12.4m オフセット					17.4m オフセット				
	5°	15°	30°	45°	60°	5°	15°	30°	45°	60°	5°	15°	30°	45°	60°
9.0	6.3														
10.0	6.3	6.3													
11.0	6.3	6.3				4.3									
12.0	6.3	6.3	6.3			4.3					2.9				
14.0	6.3	6.3	6.3	6.0		4.3	4.3				2.9				
16.0	6.3	6.3	6.1	5.9	4.4	4.3	4.3	3.8			2.9	2.8			
18.0	6.3	6.0	5.7	5.6	4.4	4.3	4.3	3.7	3.1		2.9	2.8			
20.0	5.9	5.7	5.4	5.3	4.3	4.3	4.3	3.5	3.1	2.3	2.9	2.7	2.2		
22.0	5.6	5.4	5.2	5.1	4.3	4.3	4.1	3.4	3.0	2.3	2.9	2.6	2.1		
24.0	5.3	5.1	4.9	4.8	4.2	4.3	4.0	3.3	2.9	2.3	2.8	2.5	2.1	1.8	
26.0	5.0	4.9	4.7	4.6	4.2	4.3	3.8	3.2	2.8	2.3	2.7	2.4	2.0	1.7	1.4
28.0	4.7	4.6	4.5	4.4	4.2	4.1	3.7	3.1	2.8	2.2	2.7	2.3	2.0	1.7	1.4
30.0	4.5	4.4	4.3	4.3	4.2	4.0	3.6	3.0	2.7	2.2	2.6	2.2	1.9	1.6	1.4
32.0	4.2	4.2	4.1	4.1	4.1	3.8	3.4	3.0	2.7	2.2	2.5	2.2	1.9	1.6	1.4
34.0	3.5	3.7	3.9	3.9		3.6	3.3	2.9	2.6	2.2	2.4	2.1	1.8	1.6	1.4
36.0	2.9	3.0	3.2	3.3		3.4	3.2	2.8	2.6	2.2	2.3	2.0	1.8	1.5	1.4
38.0	2.3	2.4	2.6	2.7		2.8	3.1	2.8	2.6	2.2	2.2	2.0	1.7	1.5	1.4
40.0	1.7	1.9	2.1	2.2		2.3	2.6	2.7	2.5		2.2	1.9	1.7	1.5	1.4
44.0	0.8	0.9	1.1	1.1		1.4	1.6	1.9	2.0		1.9	1.8	1.6	1.4	
48.0							0.8	1.0	1.1		1.2	1.4	1.5	1.4	
52.0													1.0	1.1	
θ(°)	49~85	51~85	53~85	53~85	70~85	54~85	53~85	57~85	57~85	67~85	56~85	63~85	61~85	62~85	69~85
標準フック	7.3t														
フック質量	300kg														
標準巻掛本数	1														

注) カウンタウエイト 25t、アウトリガ張出幅 7.5m

【C性能】

60.0mブーム+1.6m+フルオートラフィングジブ

単位:t

ジブ長さ 作業半径 (m)	7.4m オフセット					12.4m オフセット					17.4m オフセット				
	5°	15°	30°	45°	60°	5°	15°	30°	45°	60°	5°	15°	30°	45°	60°
9.0	5.3														
10.0	5.3														
11.0	5.3	5.3													
12.0	5.3	5.3				4.1									
14.0	5.3	5.3	5.3			4.1					2.8				
16.0	5.3	5.3	5.3	5.3		4.1	4.1				2.8	2.7			
18.0	5.3	5.3	5.3	5.1	4.4	4.1	4.1	3.6			2.8	2.6			
20.0	5.3	5.2	5.0	4.9	4.3	4.1	4.1	3.5	3.1		2.7	2.6	2.2		
22.0	5.1	4.9	4.7	4.6	4.3	4.1	4.0	3.4	3.0	2.3	2.7	2.5	2.1		
24.0	4.8	4.7	4.5	4.4	4.3	4.1	3.9	3.3	2.9	2.3	2.7	2.4	2.1		
26.0	4.5	4.4	4.3	4.2	4.2	4.0	3.8	3.2	2.9	2.3	2.6	2.4	2.0	1.7	
28.0	4.3	4.2	4.1	4.1	4.1	3.8	3.6	3.1	2.8	2.2	2.6	2.3	1.9	1.7	1.4
30.0	4.1	4.0	3.9	3.9	3.9	3.6	3.5	3.0	2.8	2.2	2.5	2.2	1.9	1.7	1.4
32.0	3.9	3.8	3.7	3.7	3.7	3.5	3.4	2.9	2.7	2.2	2.5	2.1	1.8	1.6	1.4
34.0	3.5	3.6	3.6	3.5	3.5	3.3	3.2	2.9	2.7	2.2	2.4	2.1	1.8	1.6	1.4
36.0	2.8	3.0	3.2	3.3		3.2	3.1	2.8	2.6	2.2	2.3	2.0	1.7	1.6	1.4
38.0	2.2	2.4	2.6	2.7		2.8	3.0	2.7	2.6	2.2	2.2	2.0	1.7	1.5	1.4
40.0	1.7	1.9	2.0	2.1		2.3	2.5	2.7	2.5	2.2	2.2	1.9	1.7	1.5	1.4
44.0		0.9	1.0	1.1		1.3	1.6	1.9	2.0		1.8	1.8	1.6	1.5	1.4
48.0								1.0	1.1		1.1	1.3	1.5	1.4	
52.0													0.9	1.1	
θ(°)	57~85	54~85	55~85	57~85	69~85	58~85	61~85	61~85	61~85	68~85	60~85	65~85	64~85	62~85	67~85
標準フック	7.3t														
フック質量	300kg														
標準巻掛本数	1														

注) カウンタウエイト 25t、アウトリガ張出幅 7.5m

フルオートラフィングジブ

【D性能】

43.0mブーム+1.6m+フルオートラフィングジブ

単位:t

ジブ長さ 作業半径 (m)	7.4m					12.4m					17.4m				
	オフセット					オフセット					オフセット				
	5°	15°	30°	45°	60°	5°	15°	30°	45°	60°	5°	15°	30°	45°	60°
6.0	7.3														
7.0	7.3					4.3									
8.0	7.3	7.3				4.3					3.3				
9.0	7.3	7.3	7.3			4.3					3.3				
10.0	7.3	7.3	7.3	6.2		4.3	4.3				3.3				
11.0	7.3	7.3	7.3	6.1	4.5	4.3	4.3				3.3	3.3			
12.0	7.3	7.3	7.3	6.0	4.5	4.3	4.3	4.3			3.3	3.3			
14.0	7.3	7.3	7.3	5.8	4.4	4.3	4.3	4.2			3.3	3.2			
16.0	7.3	7.3	7.3	5.7	4.4	4.3	4.3	4.0	3.1	2.4	3.3	3.1	2.5		
18.0	7.3	7.3	6.9	5.5	4.3	4.3	4.3	3.8	3.0	2.4	3.3	2.9	2.4		
20.0	7.3	7.3	6.7	5.4	4.3	4.3	4.3	3.7	3.0	2.3	3.3	2.8	2.3		
22.0	5.8	6.2	6.4	5.3	4.2	4.3	4.3	3.6	2.9	2.3	3.1	2.6	2.2	1.8	
24.0	4.5	4.8	5.2	5.2	4.2	4.3	4.1	3.4	2.8	2.3	3.0	2.5	2.1	1.7	1.5
26.0	3.4	3.7	4.0	4.2	4.2	4.2	3.9	3.3	2.7	2.2	2.8	2.4	2.1	1.7	1.4
28.0	2.5	2.8	3.0	3.2		3.3	3.7	3.2	2.7	2.2	2.7	2.3	2.0	1.6	1.4
30.0	1.8	2.0	2.2	2.4		2.5	2.9	3.1	2.6	2.2	2.6	2.2	1.9	1.6	1.4
32.0	1.2	1.3	1.5	1.6		1.9	2.2	2.6	2.6	2.2	2.5	2.2	1.8	1.5	1.4
34.0		0.8	0.9	1.0		1.3	1.6	1.9	2.1		1.9	2.1	1.8	1.5	1.4
36.0						0.8	1.1	1.4	1.5		1.4	1.8	1.7	1.5	1.4
38.0								0.9	1.0		1.0	1.3	1.7	1.5	
40.0												0.9	1.2	1.4	
θ(°)	52~85	50~85	52~85	54~85	67~85	52~85	54~85	56~85	57~85	66~85	54~85	57~85	61~85	62~85	68~85
標準フック	7.3t														
フック質量	300kg														
標準巻掛本数	1														

注) カウンタウエイト 15t、アウトリガ張出幅 7.5m

【D性能】

51.7mブーム+1.6m+フルオートラフィングジブ

単位:t

ジブ長さ 作業半径 (m)	7.4m					12.4m					17.4m				
	オフセット					オフセット					オフセット				
	5°	15°	30°	45°	60°	5°	15°	30°	45°	60°	5°	15°	30°	45°	60°
8.0	7.3														
9.0	7.3	7.3													
10.0	7.3	7.3				4.3					3.2				
11.0	7.3	7.3	7.3			4.3					3.2				
12.0	7.3	7.3	7.3	6.2		4.3	4.3				3.2				
14.0	7.3	7.3	7.3	6.0	4.5	4.3	4.3				3.2	3.1			
16.0	7.3	7.3	7.3	5.8	4.4	4.3	4.3	3.9			3.2	3.0			
18.0	7.3	7.3	7.0	5.7	4.3	4.3	4.3	3.8	3.1		3.2	2.8	2.3		
20.0	7.1	6.9	6.6	5.6	4.3	4.3	4.3	3.6	3.0	2.3	3.1	2.7	2.3		
22.0	6.0	6.4	6.3	5.4	4.3	4.3	4.2	3.5	2.9	2.3	3.0	2.6	2.2		
24.0	4.7	5.0	5.4	5.3	4.2	4.3	4.1	3.4	2.9	2.3	2.9	2.5	2.1	1.8	
26.0	3.6	3.9	4.2	4.5	4.2	4.3	3.9	3.3	2.8	2.3	2.8	2.4	2.0	1.7	1.4
28.0	2.7	3.0	3.3	3.5	3.6	3.4	3.8	3.2	2.7	2.2	2.7	2.3	2.0	1.7	1.4
30.0	2.0	2.2	2.5	2.6	2.7	2.6	3.0	3.1	2.7	2.2	2.6	2.3	1.9	1.6	1.4
32.0	1.3	1.5	1.8	1.9		2.0	2.3	2.7	2.6	2.2	2.5	2.2	1.9	1.6	1.4
34.0	0.8	1.0	1.2	1.3		1.4	1.7	2.1	2.3	2.2	1.9	2.1	1.8	1.6	1.4
36.0				0.8		0.9	1.2	1.5	1.7	1.8	1.4	1.8	1.8	1.5	1.4
38.0								1.0	1.2		1.0	1.3	1.7	1.5	1.4
40.0									0.8			0.9	1.3	1.5	1.4
44.0														0.8	
θ(°)	56~85	58~85	59~85	59~85	67~85	59~85	62~85	64~85	62~85	66~85	62~85	64~85	67~85	64~85	66~85
標準フック	7.3t														
フック質量	300kg														
標準巻掛本数	1														

注) カウンタウエイト 15t、アウトリガ張出幅 7.5m

【D性能】

56.0mブーム+1.6m+フルオートラフィングジブ

単位:t

ジブ長さ 作業半径 (m)	7.4m					12.4m					17.4m				
	オフセット					オフセット					オフセット				
	5°	15°	30°	45°	60°	5°	15°	30°	45°	60°	5°	15°	30°	45°	60°
9.0	6.3														
10.0	6.3	6.3													
11.0	6.3	6.3				4.3									
12.0	6.3	6.3	6.3			4.3					2.9				
14.0	6.3	6.3	6.3	6.0		4.3	4.3				2.9				
16.0	6.3	6.3	6.1	5.9	4.4	4.3	4.3	3.8			2.9	2.8			
18.0	6.3	6.0	5.7	5.6	4.4	4.3	4.3	3.7	3.1		2.9	2.8			
20.0	5.9	5.7	5.4	5.3	4.3	4.3	4.3	3.5	3.1	2.3	2.9	2.7	2.2		
22.0	5.6	5.4	5.2	5.1	4.3	4.3	4.1	3.4	3.0	2.3	2.9	2.6	2.1		
24.0	4.9	5.1	4.9	4.8	4.2	4.3	4.0	3.3	2.9	2.3	2.8	2.5	2.1	1.8	
26.0	3.9	4.1	4.5	4.6	4.2	4.3	3.8	3.2	2.8	2.3	2.7	2.4	2.0	1.7	1.4
28.0	3.0	3.2	3.5	3.7	3.8	3.6	3.7	3.1	2.8	2.2	2.7	2.3	2.0	1.7	1.4
30.0	2.2	2.4	2.7	2.9	3.0	2.8	3.2	3.0	2.7	2.2	2.6	2.2	1.9	1.6	1.4
32.0	1.6	1.8	2.0	2.2	2.2	2.2	2.5	2.9	2.7	2.2	2.5	2.2	1.9	1.6	1.4
34.0	1.0	1.2	1.4	1.5		1.6	1.9	2.3	2.5	2.2	2.1	2.1	1.8	1.6	1.4
36.0			0.9	1.0		1.1	1.4	1.7	1.9	2.0	1.6	1.9	1.8	1.5	1.4
38.0							0.9	1.2	1.4	1.5	1.1	1.5	1.7	1.5	1.4
40.0									1.0			1.1	1.5	1.5	1.4
44.0														0.9	
θ(°)	60~85	61~85	61~85	62~85	68~85	61~85	62~85	67~85	65~85	66~85	64~85	68~85	71~85	68~85	69~85
標準フック	7.3t														
フック質量	300kg														
標準巻掛本数	1														

注) カウンタウエイト 15t、アウトリガ張出幅 7.5m

【D性能】

60.0mブーム+1.6m+フルオートラフィングジブ

単位:t

ジブ長さ 作業半径 (m)	7.4m					12.4m					17.4m				
	オフセット					オフセット					オフセット				
	5°	15°	30°	45°	60°	5°	15°	30°	45°	60°	5°	15°	30°	45°	60°
9.0	5.3														
10.0	5.3														
11.0	5.3	5.3													
12.0	5.3	5.3				4.1									
14.0	5.3	5.3	5.3			4.1					2.8				
16.0	5.3	5.3	5.3	5.3		4.1	4.1				2.8	2.7			
18.0	5.3	5.3	5.3	5.1	4.4	4.1	4.1	3.6			2.8	2.6			
20.0	5.3	5.2	5.0	4.9	4.3	4.1	4.1	3.5	3.1		2.7	2.6	2.2		
22.0	5.1	4.9	4.7	4.6	4.3	4.1	4.0	3.4	3.0	2.3	2.7	2.5	2.1		
24.0	4.8	4.7	4.5	4.4	4.3	4.1	3.9	3.3	2.9	2.3	2.7	2.4	2.1		
26.0	3.8	4.1	4.3	4.2	4.2	4.0	3.8	3.2	2.9	2.3	2.6	2.4	2.0	1.7	
28.0	2.9	3.2	3.5	3.7	3.8	3.5	3.6	3.1	2.8	2.2	2.6	2.3	1.9	1.7	1.4
30.0	2.2	2.4	2.7	2.9	3.0	2.7	3.1	3.0	2.8	2.2	2.5	2.2	1.9	1.7	1.4
32.0	1.5	1.7	2.0	2.1	2.2	2.1	2.4	2.8	2.7	2.2	2.5	2.1	1.8	1.6	1.4
34.0		1.2	1.4	1.5	1.6	1.5	1.8	2.2	2.5	2.2	2.0	2.1	1.8	1.6	1.4
36.0							1.3	1.7	1.9	2.0	1.5	1.9	1.7	1.6	1.4
38.0								1.2	1.4	1.5		1.4	1.7	1.5	1.4
40.0													1.4	1.5	1.4
44.0															1.0
θ(°)	64~85	64~85	65~85	66~85	67~85	66~85	67~85	69~85	70~85	69~85	69~85	72~85	73~85	72~85	67~85
標準フック	7.3t														
フック質量	300kg														
標準巻掛本数	1														

注) カウンタウエイト 15t、アウトリガ張出幅 7.5m

フルオートラフィングジブ

【E性能】

43.0mブーム+1.6m+フルオートラフィングジブ

単位:t

ジブ長さ 作業半径 (m)	7.4m					12.4m					17.4m				
	オフセット					オフセット					オフセット				
	5°	15°	30°	45°	60°	5°	15°	30°	45°	60°	5°	15°	30°	45°	60°
6.0	7.3														
7.0	7.3					4.3									
8.0	7.3	7.3				4.3					3.3				
9.0	7.3	7.3	7.3			4.3					3.3				
10.0	7.3	7.3	7.3	6.2		4.3	4.3				3.3				
11.0	7.3	7.3	7.3	6.1	4.5	4.3	4.3				3.3	3.3			
12.0	7.3	7.3	7.3	6.0	4.5	4.3	4.3	4.3			3.3	3.3			
14.0	7.3	7.3	7.3	5.8	4.4	4.3	4.3	4.2			3.3	3.2			
16.0	7.0	7.3	7.3	5.7	4.4	4.3	4.3	4.0	3.1	2.4	3.3	3.1	2.5		
18.0	4.8	5.3	5.9	5.5	4.3	4.3	4.3	3.8	3.0	2.4	3.3	2.9	2.4		
20.0	3.2	3.6	4.2	4.6	4.3	4.2	4.3	3.7	3.0	2.3	3.3	2.8	2.3		
22.0	2.0	2.4	2.9	3.2	3.3	2.9	3.5	3.6	2.9	2.3	3.1	2.6	2.2	1.8	
24.0	1.1	1.4	1.8	2.1	2.2	1.9	2.4	3.1	2.8	2.3	2.6	2.5	2.1	1.7	1.5
26.0			1.0	1.2	1.3	1.2	1.6	2.2	2.6	2.2	1.8	2.4	2.1	1.7	1.4
28.0							0.9	1.4	1.8	2.0	1.2	1.7	2.0	1.6	1.4
30.0								0.8	1.1	1.2		1.1	1.7	1.6	1.4
32.0												1.1	1.5	1.5	1.4
34.0														1.0	1.2
θ(°)	63~85	64~85	63~85	65~85	65~85	64~85	64~85	65~85	67~85	67~85	65~85	67~85	69~85	68~85	70~85
標準フック	7.3t														
フック質量	300kg														
標準巻掛本数	1														

注) カウンタウエイト 6t、アウトリガ張出幅 7.5m

【E性能】

51.7mブーム+1.6m+フルオートラフィングジブ

単位:t

ジブ長さ 作業半径 (m)	7.4m					12.4m					17.4m				
	オフセット					オフセット					オフセット				
	5°	15°	30°	45°	60°	5°	15°	30°	45°	60°	5°	15°	30°	45°	60°
8.0	7.3														
9.0	7.3	7.3													
10.0	7.3	7.3				4.3					3.2				
11.0	7.3	7.3	7.3			4.3					3.2				
12.0	7.3	7.3	7.3	6.2		4.3	4.3				3.2				
14.0	7.3	7.3	7.3	6.0	4.5	4.3	4.3				3.2	3.1			
16.0	7.2	7.3	7.3	5.8	4.4	4.3	4.3	3.9			3.2	3.0			
18.0	5.0	5.5	6.2	5.7	4.3	4.3	4.3	3.8	3.1		3.2	2.8	2.3		
20.0	3.5	3.9	4.4	4.8	4.3	4.3	4.3	3.6	3.0	2.3	3.1	2.7	2.3		
22.0	2.3	2.6	3.1	3.4	3.6	3.0	3.6	3.5	2.9	2.3	3.0	2.6	2.2		
24.0	1.3	1.6	2.0	2.3	2.5	2.0	2.6	3.2	2.9	2.3	2.7	2.5	2.1	1.8	
26.0		0.8	1.2	1.4	1.6	1.3	1.7	2.3	2.8	2.3	1.8	2.4	2.0	1.7	1.4
28.0					0.8		1.0	1.5	1.9	2.2	1.2	1.7	2.0	1.7	1.4
30.0								0.9	1.2	1.4		1.1	1.8	1.6	1.4
32.0										0.8			1.2	1.6	1.4
34.0														1.1	1.3
36.0															0.8
θ(°)	67~85	66~85	68~85	70~85	68~85	69~85	69~85	71~85	72~85	69~85	70~85	72~85	73~85	73~85	70~85
標準フック	7.3t														
フック質量	300kg														
標準巻掛本数	1														

注) カウンタウエイト 6t、アウトリガ張出幅 7.5m

【E性能】

56.0mブーム+1.6m+フルオートラフィングジブ

単位:t

ジブ長さ 作業半径 (m)	7.4m					12.4m					17.4m				
	オフセット					オフセット					オフセット				
	5°	15°	30°	45°	60°	5°	15°	30°	45°	60°	5°	15°	30°	45°	60°
9.0	6.3														
10.0	6.3	6.3													
11.0	6.3	6.3				4.3									
12.0	6.3	6.3	6.3			4.3					2.9				
14.0	6.3	6.3	6.3	6.0		4.3	4.3				2.9				
16.0	6.3	6.3	6.1	5.9	4.4	4.3	4.3	3.8			2.9	2.8			
18.0	5.3	5.8	5.7	5.6	4.4	4.3	4.3	3.7	3.1		2.9	2.8			
20.0	3.7	4.1	4.7	5.1	4.3	4.3	4.3	3.5	3.1	2.3	2.9	2.7	2.2		
22.0	2.5	2.9	3.3	3.7	3.9	3.2	3.8	3.4	3.0	2.3	2.9	2.6	2.1		
24.0	1.6	1.9	2.3	2.6	2.7	2.2	2.7	3.3	2.9	2.3	2.8	2.5	2.1	1.8	
26.0		1.1	1.4	1.7	1.8	1.4	1.9	2.5	2.8	2.3	2.0	2.4	2.0	1.7	1.4
28.0				0.9	1.1		1.2	1.7	2.1	2.2	1.3	1.9	2.0	1.7	1.4
30.0								1.1	1.4	1.6		1.3	1.9	1.6	1.4
32.0									0.8	1.0			1.3	1.6	1.4
34.0													0.8	1.2	1.4
36.0															1.0
θ(°)	69~85	69~85	70~85	69~85	70~85	71~85	71~85	73~85	71~85	71~85	71~85	75~85	73~85	76~85	73~85
標準フック	7.3t														
フック質量	300kg														
標準巻掛本数	1														

注) カウンタウエイト 6t、アウトリガ張出幅 7.5m

【E性能】

60.0mブーム+1.6m+フルオートラフィングジブ

単位:t

ジブ長さ 作業半径 (m)	7.4m					12.4m					17.4m				
	オフセット					オフセット					オフセット				
	5°	15°	30°	45°	60°	5°	15°	30°	45°	60°	5°	15°	30°	45°	60°
9.0	5.3														
10.0	5.3														
11.0	5.3	5.3													
12.0	5.3	5.3				4.1									
14.0	5.3	5.3	5.3			4.1					2.8				
16.0	5.3	5.3	5.3	5.3		4.1	4.1				2.8	2.7			
18.0	5.3	5.3	5.3	5.1	4.4	4.1	4.1	3.6			2.8	2.6			
20.0	3.7	4.1	4.6	4.9	4.3	4.1	4.1	3.5	3.1		2.7	2.6	2.2		
22.0	2.5	2.8	3.3	3.6	3.9	3.1	3.7	3.4	3.0	2.3	2.7	2.5	2.1		
24.0	1.5	1.8	2.2	2.5	2.7	2.2	2.7	3.3	2.9	2.3	2.7	2.4	2.1		
26.0			1.4	1.7	1.8	1.4	1.8	2.4	2.9	2.3	1.9	2.4	2.0	1.7	
28.0								1.7	2.1	2.2	1.2	1.8	1.9	1.7	1.4
30.0									1.4	1.6		1.2	1.8	1.7	1.4
32.0													1.3	1.6	1.4
34.0														1.2	1.4
36.0															0.9
θ(°)	71~85	72~85	72~85	73~85	74~85	72~85	74~85	77~85	75~85	75~85	74~85	76~85	77~85	76~85	74~85
標準フック	7.3t														
フック質量	300kg														
標準巻掛本数	1														

注) カウンタウエイト 6t、アウトリガ張出幅 7.5m

フルオートラフィングジブ

【F性能】

43.0mブーム+1.6m+フルオートラフィングジブ

単位:t

ジブ長さ 作業半径 (m)	7.4m					12.4m					17.4m				
	オフセット					オフセット					オフセット				
	5°	15°	30°	45°	60°	5°	15°	30°	45°	60°	5°	15°	30°	45°	60°
6.0	7.3														
7.0	7.3					4.3									
8.0	7.3	7.3				4.3					3.3				
9.0	7.3	7.3	7.3			4.3					3.3				
10.0	7.3	7.3	7.3	6.2		4.3	4.3				3.3				
11.0	7.3	7.3	7.3	6.1	4.5	4.3	4.3				3.3	3.3			
12.0	7.3	7.3	7.3	6.0	4.5	4.3	4.3	4.3			3.3	3.3			
14.0	7.3	7.3	7.3	5.8	4.4	4.3	4.3	4.2			3.3	3.2			
16.0	7.3	7.3	7.3	5.7	4.4	4.3	4.3	4.0	3.1	2.4	3.3	3.1	2.5		
18.0	7.3	7.3	6.9	5.5	4.3	4.3	4.3	3.8	3.0	2.4	3.3	2.9	2.4		
20.0	7.3	7.3	6.7	5.4	4.3	4.3	4.3	3.7	3.0	2.3	3.3	2.8	2.3		
22.0	7.3	7.3	6.4	5.3	4.2	4.3	4.3	3.6	2.9	2.3	3.1	2.6	2.2	1.8	
24.0	7.3	7.3	6.2	5.2	4.2	4.3	4.1	3.4	2.8	2.3	3.0	2.5	2.1	1.7	1.5
26.0	7.3	7.1	6.0	5.1	4.2	4.3	3.9	3.3	2.7	2.2	2.8	2.4	2.1	1.7	1.4
28.0	7.1	6.8	5.8	5.0		4.3	3.8	3.2	2.7	2.2	2.7	2.3	2.0	1.6	1.4
30.0	6.2	6.5	5.6	5.0		4.2	3.6	3.1	2.6	2.2	2.6	2.2	1.9	1.6	1.4
32.0	5.2	5.5	5.5	4.9		4.0	3.5	3.0	2.6	2.2	2.5	2.2	1.8	1.5	1.4
34.0	4.4	4.6	4.8	4.9		3.7	3.4	2.9	2.5		2.4	2.1	1.8	1.5	1.4
36.0	3.6	3.8	3.9	4.0		3.5	3.2	2.8	2.5		2.3	2.0	1.7	1.5	1.4
38.0	3.0	3.1	3.2			3.3	3.1	2.7	2.5		2.2	2.0	1.7	1.5	
40.0	2.4	2.5	2.6			3.1	3.0	2.7	2.5		2.1	1.9	1.6	1.4	
44.0	1.3	1.4				2.1	2.3	2.4			2.0	1.8	1.5	1.4	
48.0						1.2	1.4	1.4			1.8	1.7	1.5		
52.0											1.2	1.3	1.4		
θ(°)	30~85	31~85	43~85	54~85	67~85	33~85	36~85	42~85	56~85	66~85	35~85	43~85	46~85	57~85	68~85
標準フック	7.3t														
フック質量	300kg														
標準巻掛本数	1														

注) カウンタウエイト 40t、アウトリガ張出幅 6.2m

【F性能】

51.7mブーム+1.6m+フルオートラフィングジブ

単位:t

ジブ長さ 作業半径 (m)	7.4m					12.4m					17.4m				
	オフセット					オフセット					オフセット				
	5°	15°	30°	45°	60°	5°	15°	30°	45°	60°	5°	15°	30°	45°	60°
8.0	7.3														
9.0	7.3	7.3													
10.0	7.3	7.3				4.3					3.2				
11.0	7.3	7.3	7.3			4.3					3.2				
12.0	7.3	7.3	7.3	6.2		4.3	4.3				3.2				
14.0	7.3	7.3	7.3	6.0	4.5	4.3	4.3				3.2	3.1			
16.0	7.3	7.3	7.3	5.8	4.4	4.3	4.3	3.9			3.2	3.0			
18.0	7.3	7.3	7.0	5.7	4.3	4.3	4.3	3.8	3.1		3.2	2.8	2.3		
20.0	7.1	6.9	6.6	5.6	4.3	4.3	4.3	3.6	3.0	2.3	3.1	2.7	2.3		
22.0	6.7	6.5	6.3	5.4	4.3	4.3	4.2	3.5	2.9	2.3	3.0	2.6	2.2		
24.0	6.3	6.2	6.0	5.3	4.2	4.3	4.1	3.4	2.9	2.3	2.9	2.5	2.1	1.8	
26.0	6.0	5.8	5.7	5.2	4.2	4.3	3.9	3.3	2.8	2.3	2.8	2.4	2.0	1.7	1.4
28.0	5.6	5.5	5.4	5.2	4.2	4.3	3.8	3.2	2.7	2.2	2.7	2.3	2.0	1.7	1.4
30.0	5.3	5.2	5.1	5.0	4.2	4.2	3.6	3.1	2.7	2.2	2.6	2.3	1.9	1.6	1.4
32.0	5.0	4.9	4.8	4.7		4.0	3.5	3.0	2.6	2.2	2.5	2.2	1.9	1.6	1.4
34.0	4.6	4.6	4.5	4.5		3.9	3.4	3.0	2.6	2.2	2.4	2.1	1.8	1.6	1.4
36.0	3.8	4.0	4.2	4.3		3.7	3.3	2.9	2.6	2.2	2.3	2.0	1.8	1.5	1.4
38.0	3.2	3.3	3.5	3.6		3.6	3.2	2.8	2.5		2.2	2.0	1.7	1.5	1.4
40.0	2.6	2.7	2.9	2.9		3.2	3.1	2.8	2.5		2.2	1.9	1.7	1.5	1.4
44.0	1.5	1.6	1.8			2.2	2.4	2.6	2.5		2.0	1.8	1.6	1.4	
48.0		0.8	0.9			1.3	1.5	1.7			1.9	1.7	1.6	1.4	
52.0							0.8	0.9			1.2	1.4	1.5	1.4	
56.0													0.9		
θ(°)	45~85	39~85	41~85	57~85	69~85	46~85	43~85	49~85	62~85	67~85	48~85	55~85	50~85	57~85	66~85
標準フック	7.3t														
フック質量	300kg														
標準巻掛本数	1														

注) カウンタウエイト 40t、アウトリガ張出幅 6.2m

【F性能】

56.0mブーム+1.6m+フルオートラフィングジブ

単位:t

ジブ長さ 作業半径 (m)	7.4m					12.4m					17.4m				
	オフセット					オフセット					オフセット				
	5°	15°	30°	45°	60°	5°	15°	30°	45°	60°	5°	15°	30°	45°	60°
9.0	6.3														
10.0	6.3	6.3													
11.0	6.3	6.3				4.3									
12.0	6.3	6.3	6.3			4.3					2.9				
14.0	6.3	6.3	6.3	6.0		4.3	4.3				2.9				
16.0	6.3	6.3	6.1	5.9	4.4	4.3	4.3	3.8			2.9	2.8			
18.0	6.3	6.0	5.7	5.6	4.4	4.3	4.3	3.7	3.1		2.9	2.8			
20.0	5.9	5.7	5.4	5.3	4.3	4.3	4.3	3.5	3.1	2.3	2.9	2.7	2.2		
22.0	5.6	5.4	5.2	5.1	4.3	4.3	4.1	3.4	3.0	2.3	2.9	2.6	2.1		
24.0	5.3	5.1	4.9	4.8	4.2	4.3	4.0	3.3	2.9	2.3	2.8	2.5	2.1	1.8	
26.0	5.0	4.9	4.7	4.6	4.2	4.3	3.8	3.2	2.8	2.3	2.7	2.4	2.0	1.7	1.4
28.0	4.7	4.6	4.5	4.4	4.2	4.1	3.7	3.1	2.8	2.2	2.7	2.3	2.0	1.7	1.4
30.0	4.5	4.4	4.3	4.3	4.2	4.0	3.6	3.0	2.7	2.2	2.6	2.2	1.9	1.6	1.4
32.0	4.3	4.2	4.1	4.1	4.1	3.8	3.4	3.0	2.7	2.2	2.5	2.2	1.9	1.6	1.4
34.0	4.1	4.0	3.9	3.9		3.6	3.3	2.9	2.6	2.2	2.4	2.1	1.8	1.6	1.4
36.0	3.9	3.8	3.7	3.7		3.5	3.2	2.8	2.6	2.2	2.3	2.0	1.8	1.5	1.4
38.0	3.4	3.6	3.6	3.6		3.3	3.1	2.8	2.6	2.2	2.2	2.0	1.7	1.5	1.4
40.0	2.8	3.0	3.1	3.2		3.2	3.1	2.7	2.5		2.2	1.9	1.7	1.5	1.4
44.0	1.8	1.9	2.0	2.1		2.4	2.6	2.6	2.5		2.0	1.8	1.6	1.4	
48.0	0.9	1.0	1.1			1.5	1.7	1.9	2.0		1.9	1.7	1.5	1.4	
52.0						0.8	1.0	1.1			1.3	1.5	1.5	1.4	
56.0												0.9	1.1		
θ(°)	44~85	46~85	48~85	55~85	70~85	45~85	49~85	54~85	59~85	67~85	53~85	56~85	57~85	63~85	69~85
標準フック	7.3t														
フック質量	300kg														
標準巻掛本数	1														

注) カウンタウエイト 40t、アウトリガ張出幅 6.2m

【F性能】

60.0mブーム+1.6m+フルオートラフィングジブ

単位:t

ジブ長さ 作業半径 (m)	7.4m					12.4m					17.4m				
	オフセット					オフセット					オフセット				
	5°	15°	30°	45°	60°	5°	15°	30°	45°	60°	5°	15°	30°	45°	60°
9.0	5.3														
10.0	5.3														
11.0	5.3	5.3													
12.0	5.3	5.3				4.1									
14.0	5.3	5.3	5.3			4.1					2.8				
16.0	5.3	5.3	5.3	5.3		4.1	4.1				2.8	2.7			
18.0	5.3	5.3	5.3	5.1	4.4	4.1	4.1	3.6			2.8	2.6			
20.0	5.3	5.2	5.0	4.9	4.3	4.1	4.1	3.5	3.1		2.7	2.6	2.2		
22.0	5.1	4.9	4.7	4.6	4.3	4.1	4.0	3.4	3.0	2.3	2.7	2.5	2.1		
24.0	4.8	4.7	4.5	4.4	4.3	4.1	3.9	3.3	2.9	2.3	2.7	2.4	2.1		
26.0	4.5	4.4	4.3	4.2	4.2	4.0	3.8	3.2	2.9	2.3	2.6	2.4	2.0	1.7	
28.0	4.3	4.2	4.1	4.1	4.1	3.8	3.6	3.1	2.8	2.2	2.6	2.3	1.9	1.7	1.4
30.0	4.1	4.0	3.9	3.9	3.9	3.6	3.5	3.0	2.8	2.2	2.5	2.2	1.9	1.7	1.4
32.0	3.9	3.8	3.7	3.7	3.7	3.5	3.4	2.9	2.7	2.2	2.5	2.1	1.8	1.6	1.4
34.0	3.7	3.6	3.6	3.5	3.5	3.3	3.2	2.9	2.7	2.2	2.4	2.1	1.8	1.6	1.4
36.0	3.5	3.5	3.4	3.4		3.2	3.1	2.8	2.6	2.2	2.3	2.0	1.7	1.6	1.4
38.0	3.4	3.3	3.2	3.2		3.0	3.0	2.7	2.6	2.2	2.2	2.0	1.7	1.5	1.4
40.0	2.8	2.9	3.1	3.1		2.9	2.8	2.7	2.5	2.2	2.2	1.9	1.7	1.5	1.4
44.0	1.7	1.9	2.0	2.1		2.3	2.4	2.4	2.4		2.0	1.8	1.6	1.5	1.4
48.0	0.9	1.0	1.1	1.2		1.5	1.7	1.9	2.0		1.9	1.7	1.5	1.4	
52.0							0.9	1.1	1.2		1.2	1.5	1.5	1.4	
56.0												0.8	1.1	1.2	
θ(°)	48~85	50~85	51~85	53~85	69~85	54~85	53~85	58~85	58~85	68~85	58~85	58~85	61~85	59~85	67~85
標準フック	7.3t														
フック質量	300kg														
標準巻掛本数	1														

注) カウンタウエイト 40t、アウトリガ張出幅 6.2m

フルオートラフィングジブ

【G性能】

43.0mブーム+1.6m+フルオートラフィングジブ

単位:t

ジブ長さ 作業半径 (m)	7.4m					12.4m					17.4m				
	オフセット					オフセット					オフセット				
	5°	15°	30°	45°	60°	5°	15°	30°	45°	60°	5°	15°	30°	45°	60°
6.0	7.3														
7.0	7.3					4.3									
8.0	7.3	7.3				4.3					3.3				
9.0	7.3	7.3	7.3			4.3					3.3				
10.0	7.3	7.3	7.3	6.2		4.3	4.3				3.3				
11.0	7.3	7.3	7.3	6.1	4.5	4.3	4.3				3.3	3.3			
12.0	7.3	7.3	7.3	6.0	4.5	4.3	4.3	4.3			3.3	3.3			
14.0	7.3	7.3	7.3	5.8	4.4	4.3	4.3	4.2			3.3	3.2			
16.0	7.3	7.3	7.3	5.7	4.4	4.3	4.3	4.0	3.1	2.4	3.3	3.1	2.5		
18.0	7.3	7.3	6.9	5.5	4.3	4.3	4.3	3.8	3.0	2.4	3.3	2.9	2.4		
20.0	7.3	7.3	6.7	5.4	4.3	4.3	4.3	3.7	3.0	2.3	3.3	2.8	2.3		
22.0	7.3	7.3	6.4	5.3	4.2	4.3	4.3	3.6	2.9	2.3	3.1	2.6	2.2	1.8	
24.0	7.0	7.3	6.2	5.2	4.2	4.3	4.1	3.4	2.8	2.3	3.0	2.5	2.1	1.7	1.5
26.0	5.8	6.1	6.0	5.1	4.2	4.3	3.9	3.3	2.7	2.2	2.8	2.4	2.1	1.7	1.4
28.0	4.7	4.9	5.2	5.0		4.3	3.8	3.2	2.7	2.2	2.7	2.3	2.0	1.6	1.4
30.0	3.7	3.9	4.2	4.4		4.2	3.6	3.1	2.6	2.2	2.6	2.2	1.9	1.6	1.4
32.0	2.9	3.1	3.3	3.4		3.7	3.5	3.0	2.6	2.2	2.5	2.2	1.8	1.5	1.4
34.0	2.2	2.3	2.5	2.6		3.0	3.3	2.9	2.5		2.4	2.1	1.8	1.5	1.4
36.0	1.5	1.7	1.9	1.9		2.4	2.6	2.8	2.5		2.3	2.0	1.7	1.5	1.4
38.0	1.0	1.1	1.3			1.8	2.0	2.3	2.5		2.2	2.0	1.7	1.5	
40.0						1.3	1.5	1.8	1.9		1.9	1.9	1.6	1.4	
44.0								0.8			1.1	1.3	1.5	1.4	
48.0													0.8		
θ(°)	42~85	43~85	45~85	52~85	67~85	46~85	49~85	47~85	55~85	66~85	47~85	53~85	50~85	57~85	68~85
標準フック	7.3t														
フック質量	300kg														
標準巻掛本数	1														

注) カウンタウエイト 28t、アウトリガ張出幅 6.2m

【G性能】

51.7mブーム+1.6m+フルオートラフィングジブ

単位:t

ジブ長さ 作業半径 (m)	7.4m					12.4m					17.4m				
	オフセット					オフセット					オフセット				
	5°	15°	30°	45°	60°	5°	15°	30°	45°	60°	5°	15°	30°	45°	60°
8.0	7.3														
9.0	7.3	7.3													
10.0	7.3	7.3				4.3					3.2				
11.0	7.3	7.3	7.3			4.3					3.2				
12.0	7.3	7.3	7.3	6.2		4.3	4.3				3.2				
14.0	7.3	7.3	7.3	6.0	4.5	4.3	4.3				3.2	3.1			
16.0	7.3	7.3	7.3	5.8	4.4	4.3	4.3	3.9			3.2	3.0			
18.0	7.3	7.3	7.0	5.7	4.3	4.3	4.3	3.8	3.1		3.2	2.8	2.3		
20.0	7.1	6.9	6.6	5.6	4.3	4.3	4.3	3.6	3.0	2.3	3.1	2.7	2.3		
22.0	6.7	6.5	6.3	5.4	4.3	4.3	4.2	3.5	2.9	2.3	3.0	2.6	2.2		
24.0	6.3	6.2	6.0	5.3	4.2	4.3	4.1	3.4	2.9	2.3	2.9	2.5	2.1	1.8	
26.0	6.0	5.8	5.7	5.2	4.2	4.3	3.9	3.3	2.8	2.3	2.8	2.4	2.0	1.7	1.4
28.0	4.9	5.1	5.4	5.2	4.2	4.3	3.8	3.2	2.7	2.2	2.7	2.3	2.0	1.7	1.4
30.0	3.9	4.2	4.5	4.7	4.2	4.2	3.6	3.1	2.7	2.2	2.6	2.3	1.9	1.6	1.4
32.0	3.1	3.3	3.6	3.8		3.8	3.5	3.0	2.6	2.2	2.5	2.2	1.9	1.6	1.4
34.0	2.4	2.6	2.8	3.0		3.1	3.4	3.0	2.6	2.2	2.4	2.1	1.8	1.6	1.4
36.0	1.8	1.9	2.1	2.3		2.4	2.8	2.9	2.6	2.2	2.3	2.0	1.8	1.5	1.4
38.0	1.2	1.4	1.5	1.6		1.9	2.2	2.5	2.5		2.2	2.0	1.7	1.5	1.4
40.0		0.9	1.0	1.1		1.4	1.6	1.9	2.1		2.0	1.9	1.7	1.5	1.4
44.0								1.0	1.1		1.1	1.4	1.6	1.4	
48.0													0.9	1.1	
θ(°)	52~85	51~85	52~85	54~85	69~85	55~85	58~85	58~85	59~85	67~85	56~85	62~85	59~85	60~85	66~85
標準フック	7.3t														
フック質量	300kg														
標準巻掛本数	1														

注) カウンタウエイト 28t、アウトリガ張出幅 6.2m

【G性能】

56.0mブーム+1.6m+フルオートラフィングジブ

単位:t

ジブ長さ 作業半径 (m)	7.4m					12.4m					17.4m				
	オフセット					オフセット					オフセット				
	5°	15°	30°	45°	60°	5°	15°	30°	45°	60°	5°	15°	30°	45°	60°
9.0	6.3														
10.0	6.3	6.3													
11.0	6.3	6.3				4.3									
12.0	6.3	6.3	6.3			4.3					2.9				
14.0	6.3	6.3	6.3	6.0		4.3	4.3				2.9				
16.0	6.3	6.3	6.1	5.9	4.4	4.3	4.3	3.8			2.9	2.8			
18.0	6.3	6.0	5.7	5.6	4.4	4.3	4.3	3.7	3.1		2.9	2.8			
20.0	5.9	5.7	5.4	5.3	4.3	4.3	4.3	3.5	3.1	2.3	2.9	2.7	2.2		
22.0	5.6	5.4	5.2	5.1	4.3	4.3	4.1	3.4	3.0	2.3	2.9	2.6	2.1		
24.0	5.3	5.1	4.9	4.8	4.2	4.3	4.0	3.3	2.9	2.3	2.8	2.5	2.1	1.8	
26.0	5.0	4.9	4.7	4.6	4.2	4.3	3.8	3.2	2.8	2.3	2.7	2.4	2.0	1.7	1.4
28.0	4.7	4.6	4.5	4.4	4.2	4.1	3.7	3.1	2.8	2.2	2.7	2.3	2.0	1.7	1.4
30.0	4.2	4.4	4.3	4.3	4.2	4.0	3.6	3.0	2.7	2.2	2.6	2.2	1.9	1.6	1.4
32.0	3.4	3.6	3.9	4.0	4.1	3.8	3.4	3.0	2.7	2.2	2.5	2.2	1.9	1.6	1.4
34.0	2.6	2.8	3.1	3.3		3.3	3.3	2.9	2.6	2.2	2.4	2.1	1.8	1.6	1.4
36.0	2.0	2.2	2.4	2.6		2.6	3.0	2.8	2.6	2.2	2.3	2.0	1.8	1.5	1.4
38.0	1.5	1.6	1.8	1.9		2.1	2.4	2.7	2.6	2.2	2.2	2.0	1.7	1.5	1.4
40.0	1.0	1.1	1.3	1.4		1.6	1.8	2.2	2.4		2.1	1.9	1.7	1.5	1.4
44.0							0.9	1.2	1.3		1.2	1.6	1.6	1.4	
48.0													1.1	1.3	
θ(°)	53~85	55~85	57~85	58~85	70~85	58~85	57~85	61~85	62~85	67~85	59~85	67~85	64~85	65~85	69~85
標準フック	7.3t														
フック質量	300kg														
標準巻掛本数	1														

注) カウンタウエイト 28t、アウトリガ張出幅 6.2m

【G性能】

60.0mブーム+1.6m+フルオートラフィングジブ

単位:t

ジブ長さ 作業半径 (m)	7.4m					12.4m					17.4m				
	オフセット					オフセット					オフセット				
	5°	15°	30°	45°	60°	5°	15°	30°	45°	60°	5°	15°	30°	45°	60°
9.0	5.3														
10.0	5.3														
11.0	5.3	5.3													
12.0	5.3	5.3				4.1									
14.0	5.3	5.3	5.3			4.1					2.8				
16.0	5.3	5.3	5.3	5.3		4.1	4.1				2.8	2.7			
18.0	5.3	5.3	5.3	5.1	4.4	4.1	4.1	3.6			2.8	2.6			
20.0	5.3	5.2	5.0	4.9	4.3	4.1	4.1	3.5	3.1		2.7	2.6	2.2		
22.0	5.1	4.9	4.7	4.6	4.3	4.1	4.0	3.4	3.0	2.3	2.7	2.5	2.1		
24.0	4.8	4.7	4.5	4.4	4.3	4.1	3.9	3.3	2.9	2.3	2.7	2.4	2.1		
26.0	4.5	4.4	4.3	4.2	4.2	4.0	3.8	3.2	2.9	2.3	2.6	2.4	2.0	1.7	
28.0	4.3	4.2	4.1	4.1	4.1	3.8	3.6	3.1	2.8	2.2	2.6	2.3	1.9	1.7	1.4
30.0	4.1	4.0	3.9	3.9	3.9	3.6	3.5	3.0	2.8	2.2	2.5	2.2	1.9	1.7	1.4
32.0	3.3	3.5	3.7	3.7	3.7	3.5	3.4	2.9	2.7	2.2	2.5	2.1	1.8	1.6	1.4
34.0	2.6	2.8	3.1	3.2	3.3	3.2	3.2	2.9	2.7	2.2	2.4	2.1	1.8	1.6	1.4
36.0	2.0	2.2	2.4	2.5		2.6	2.9	2.8	2.6	2.2	2.3	2.0	1.7	1.6	1.4
38.0	1.4	1.6	1.8	1.9		2.0	2.3	2.7	2.6	2.2	2.2	2.0	1.7	1.5	1.4
40.0			1.3	1.4		1.5	1.8	2.1	2.3	2.2	2.0	1.9	1.7	1.5	1.4
44.0								1.2	1.3		1.1	1.5	1.6	1.5	1.4
48.0														1.3	
θ(°)	59~85	60~85	60~85	61~85	69~85	61~85	64~85	65~85	65~85	68~85	63~85	68~85	71~85	66~85	67~85
標準フック	7.3t														
フック質量	300kg														
標準巻掛本数	1														

注) カウンタウエイト 28t、アウトリガ張出幅 6.2m

フルオートラフィングジブ

【H性能】

43.0mブーム+1.6m+フルオートラフィングジブ

単位:t

ジブ長さ 作業半径 (m)	7.4m					12.4m					17.4m				
	オフセット					オフセット					オフセット				
	5°	15°	30°	45°	60°	5°	15°	30°	45°	60°	5°	15°	30°	45°	60°
6.0	7.3														
7.0	7.3					4.3									
8.0	7.3	7.3				4.3					3.3				
9.0	7.3	7.3	7.3			4.3					3.3				
10.0	7.3	7.3	7.3	6.2		4.3	4.3				3.3				
11.0	7.3	7.3	7.3	6.1	4.5	4.3	4.3				3.3	3.3			
12.0	7.3	7.3	7.3	6.0	4.5	4.3	4.3	4.3			3.3	3.3			
14.0	7.3	7.3	7.3	5.8	4.4	4.3	4.3	4.2			3.3	3.2			
16.0	7.3	7.3	7.3	5.7	4.4	4.3	4.3	4.0	3.1	2.4	3.3	3.1	2.5		
18.0	7.3	7.3	6.9	5.5	4.3	4.3	4.3	3.8	3.0	2.4	3.3	2.9	2.4		
20.0	7.3	7.3	6.7	5.4	4.3	4.3	4.3	3.7	3.0	2.3	3.3	2.8	2.3		
22.0	7.3	7.3	6.4	5.3	4.2	4.3	4.3	3.6	2.9	2.3	3.1	2.6	2.2	1.8	
24.0	6.3	6.5	6.2	5.2	4.2	4.3	4.1	3.4	2.8	2.3	3.0	2.5	2.1	1.7	1.5
26.0	5.0	5.3	5.7	5.1	4.2	4.3	3.9	3.3	2.7	2.2	2.8	2.4	2.1	1.7	1.4
28.0	4.0	4.2	4.5	4.7		4.3	3.8	3.2	2.7	2.2	2.7	2.3	2.0	1.6	1.4
30.0	3.1	3.3	3.6	3.7		3.9	3.6	3.1	2.6	2.2	2.6	2.2	1.9	1.6	1.4
32.0	2.3	2.5	2.7	2.8		3.1	3.5	3.0	2.6	2.2	2.5	2.2	1.8	1.5	1.4
34.0	1.6	1.8	2.0	2.1		2.4	2.7	2.9	2.5		2.4	2.1	1.8	1.5	1.4
36.0	1.0	1.2	1.3	1.4		1.8	2.1	2.4	2.5		2.3	2.0	1.7	1.5	1.4
38.0			0.8			1.3	1.5	1.8	2.0		2.0	2.0	1.7	1.5	
40.0						0.8	1.0	1.3	1.4		1.5	1.8	1.6	1.4	
44.0												0.9	1.2	1.4	
θ(°)	45~85	47~85	45~85	51~85	67~85	46~85	49~85	54~85	54~85	66~85	52~85	53~85	56~85	57~85	68~85
標準フック	7.3t														
フック質量	300kg														
標準巻掛本数	1														

注) カウンタウエイト 25t、アウトリガ張出幅 6.2m

【H性能】

51.7mブーム+1.6m+フルオートラフィングジブ

単位:t

ジブ長さ 作業半径 (m)	7.4m					12.4m					17.4m				
	オフセット					オフセット					オフセット				
	5°	15°	30°	45°	60°	5°	15°	30°	45°	60°	5°	15°	30°	45°	60°
8.0	7.3														
9.0	7.3	7.3													
10.0	7.3	7.3				4.3					3.2				
11.0	7.3	7.3	7.3			4.3					3.2				
12.0	7.3	7.3	7.3	6.2		4.3	4.3				3.2				
14.0	7.3	7.3	7.3	6.0	4.5	4.3	4.3				3.2	3.1			
16.0	7.3	7.3	7.3	5.8	4.4	4.3	4.3	3.9			3.2	3.0			
18.0	7.3	7.3	7.0	5.7	4.3	4.3	4.3	3.8	3.1		3.2	2.8	2.3		
20.0	7.1	6.9	6.6	5.6	4.3	4.3	4.3	3.6	3.0	2.3	3.1	2.7	2.3		
22.0	6.7	6.5	6.3	5.4	4.3	4.3	4.2	3.5	2.9	2.3	3.0	2.6	2.2		
24.0	6.3	6.2	6.0	5.3	4.2	4.3	4.1	3.4	2.9	2.3	2.9	2.5	2.1	1.8	
26.0	5.2	5.5	5.7	5.2	4.2	4.3	3.9	3.3	2.8	2.3	2.8	2.4	2.0	1.7	1.4
28.0	4.2	4.4	4.8	5.0	4.2	4.3	3.8	3.2	2.7	2.2	2.7	2.3	2.0	1.7	1.4
30.0	3.3	3.5	3.8	4.0	4.1	4.0	3.6	3.1	2.7	2.2	2.6	2.3	1.9	1.6	1.4
32.0	2.5	2.7	3.0	3.2		3.2	3.5	3.0	2.6	2.2	2.5	2.2	1.9	1.6	1.4
34.0	1.8	2.0	2.3	2.4		2.5	2.9	3.0	2.6	2.2	2.4	2.1	1.8	1.6	1.4
36.0	1.2	1.4	1.6	1.7		1.9	2.2	2.6	2.6	2.2	2.3	2.0	1.8	1.5	1.4
38.0			1.0	1.1		1.4	1.7	2.0	2.2		2.0	2.0	1.7	1.5	1.4
40.0							1.2	1.5	1.7		1.5	1.9	1.7	1.5	1.4
44.0												1.0	1.4	1.4	
θ(°)	54~85	56~85	55~85	57~85	68~85	57~85	58~85	63~85	64~85	67~85	60~85	61~85	63~85	65~85	66~85
標準フック	7.3t														
フック質量	300kg														
標準巻掛本数	1														

注) カウンタウエイト 25t、アウトリガ張出幅 6.2m

【H性能】

56.0mブーム+1.6m+フルオートラフィングジブ

単位:t

ジブ長さ 作業半径 (m)	7.4m					12.4m					17.4m				
	オフセット					オフセット					オフセット				
	5°	15°	30°	45°	60°	5°	15°	30°	45°	60°	5°	15°	30°	45°	60°
9.0	6.3														
10.0	6.3	6.3													
11.0	6.3	6.3				4.3									
12.0	6.3	6.3	6.3			4.3					2.9				
14.0	6.3	6.3	6.3	6.0		4.3	4.3				2.9				
16.0	6.3	6.3	6.1	5.9	4.4	4.3	4.3	3.8			2.9	2.8			
18.0	6.3	6.0	5.7	5.6	4.4	4.3	4.3	3.7	3.1		2.9	2.8			
20.0	5.9	5.7	5.4	5.3	4.3	4.3	4.3	3.5	3.1	2.3	2.9	2.7	2.2		
22.0	5.6	5.4	5.2	5.1	4.3	4.3	4.1	3.4	3.0	2.3	2.9	2.6	2.1		
24.0	5.3	5.1	4.9	4.8	4.2	4.3	4.0	3.3	2.9	2.3	2.8	2.5	2.1	1.8	
26.0	5.0	4.9	4.7	4.6	4.2	4.3	3.8	3.2	2.8	2.3	2.7	2.4	2.0	1.7	1.4
28.0	4.4	4.6	4.5	4.4	4.2	4.1	3.7	3.1	2.8	2.2	2.7	2.3	2.0	1.7	1.4
30.0	3.5	3.8	4.1	4.3	4.2	4.0	3.6	3.0	2.7	2.2	2.6	2.2	1.9	1.6	1.4
32.0	2.8	3.0	3.3	3.4	3.5	3.4	3.4	3.0	2.7	2.2	2.5	2.2	1.9	1.6	1.4
34.0	2.1	2.3	2.5	2.7		2.7	3.1	2.9	2.6	2.2	2.4	2.1	1.8	1.6	1.4
36.0	1.5	1.7	1.9	2.0		2.1	2.4	2.8	2.6	2.2	2.3	2.0	1.8	1.5	1.4
38.0		1.1	1.3	1.4		1.6	1.9	2.2	2.5	2.2	2.1	2.0	1.7	1.5	1.4
40.0						1.1	1.4	1.7	1.9		1.6	1.9	1.7	1.5	1.4
44.0												1.1	1.5	1.4	
θ(°)	58~85	57~85	59~85	60~85	69~85	58~85	61~85	66~85	66~85	67~85	63~85	66~85	68~85	69~85	69~85
標準フック	7.3t														
フック質量	300kg														
標準巻掛本数	1														

注) カウンタウエイト 25t、アウトリガ張出幅 6.2m

【H性能】

60.0mブーム+1.6m+フルオートラフィングジブ

単位:t

ジブ長さ 作業半径 (m)	7.4m					12.4m					17.4m				
	オフセット					オフセット					オフセット				
	5°	15°	30°	45°	60°	5°	15°	30°	45°	60°	5°	15°	30°	45°	60°
9.0	5.3														
10.0	5.3														
11.0	5.3	5.3													
12.0	5.3	5.3				4.1									
14.0	5.3	5.3	5.3			4.1					2.8				
16.0	5.3	5.3	5.3	5.3		4.1	4.1				2.8	2.7			
18.0	5.3	5.3	5.3	5.1	4.4	4.1	4.1	3.6			2.8	2.6			
20.0	5.3	5.2	5.0	4.9	4.3	4.1	4.1	3.5	3.1		2.7	2.6	2.2		
22.0	5.1	4.9	4.7	4.6	4.3	4.1	4.0	3.4	3.0	2.3	2.7	2.5	2.1		
24.0	4.8	4.7	4.5	4.4	4.3	4.1	3.9	3.3	2.9	2.3	2.7	2.4	2.1		
26.0	4.5	4.4	4.3	4.2	4.2	4.0	3.8	3.2	2.9	2.3	2.6	2.4	2.0	1.7	
28.0	4.3	4.2	4.1	4.1	4.1	3.8	3.6	3.1	2.8	2.2	2.6	2.3	1.9	1.7	1.4
30.0	3.5	3.7	3.9	3.9	3.9	3.6	3.5	3.0	2.8	2.2	2.5	2.2	1.9	1.7	1.4
32.0	2.7	2.9	3.2	3.4	3.5	3.3	3.4	2.9	2.7	2.2	2.5	2.1	1.8	1.6	1.4
34.0	2.0	2.2	2.5	2.7	2.7	2.6	3.0	2.9	2.7	2.2	2.4	2.1	1.8	1.6	1.4
36.0	1.4	1.6	1.9	2.0		2.0	2.4	2.8	2.6	2.2	2.3	2.0	1.7	1.6	1.4
38.0				1.4		1.5	1.8	2.2	2.4	2.2	2.0	2.0	1.7	1.5	1.4
40.0								1.6	1.9	2.0	1.5	1.9	1.7	1.5	1.4
44.0													1.5	1.5	1.4
θ(°)	60~85	62~85	64~85	63~85	68~85	63~85	66~85	68~85	69~85	68~85	67~85	71~85	70~85	69~85	67~85
標準フック	7.3t														
フック質量	300kg														
標準巻掛本数	1														

注) カウンタウエイト 25t、アウトリガ張出幅 6.2m

フルオートラフィングジブ

【1性能】

43.0mブーム+1.6m+フルオートラフィングジブ

単位:t

ジブ長さ 作業半径 (m)	7.4m					12.4m					17.4m				
	オフセット					オフセット					オフセット				
	5°	15°	30°	45°	60°	5°	15°	30°	45°	60°	5°	15°	30°	45°	60°
6.0	7.3														
7.0	7.3					4.3									
8.0	7.3	7.3				4.3					3.3				
9.0	7.3	7.3	7.3			4.3					3.3				
10.0	7.3	7.3	7.3	6.2		4.3	4.3				3.3				
11.0	7.3	7.3	7.3	6.1	4.5	4.3	4.3				3.3	3.3			
12.0	7.3	7.3	7.3	6.0	4.5	4.3	4.3	4.3			3.3	3.3			
14.0	7.3	7.3	7.3	5.8	4.4	4.3	4.3	4.2			3.3	3.2			
16.0	7.3	7.3	7.3	5.7	4.4	4.3	4.3	4.0	3.1	2.4	3.3	3.1	2.5		
18.0	7.3	7.3	6.9	5.5	4.3	4.3	4.3	3.8	3.0	2.4	3.3	2.9	2.4		
20.0	6.3	6.7	6.7	5.4	4.3	4.3	4.3	3.7	3.0	2.3	3.3	2.8	2.3		
22.0	4.8	5.2	5.7	5.3	4.2	4.3	4.3	3.6	2.9	2.3	3.1	2.6	2.2	1.8	
24.0	3.6	3.9	4.4	4.7	4.2	4.3	4.1	3.4	2.8	2.3	3.0	2.5	2.1	1.7	1.5
26.0	2.6	2.9	3.2	3.5	3.6	3.5	3.9	3.3	2.7	2.2	2.8	2.4	2.1	1.7	1.4
28.0	1.7	2.0	2.3	2.5		2.6	3.0	3.2	2.7	2.2	2.7	2.3	2.0	1.6	1.4
30.0			1.5	1.7		1.8	2.2	2.7	2.6	2.2	2.5	2.2	1.9	1.6	1.4
32.0							1.5	2.0	2.3	2.2	1.9	2.2	1.8	1.5	1.4
34.0								1.3	1.6		1.3	1.8	1.8	1.5	1.4
36.0												1.2	1.7	1.5	1.4
38.0													1.2	1.5	
θ(°)	57~85	59~85	57~85	60~85	66~85	59~85	59~85	61~85	62~85	66~85	59~85	62~85	63~85	65~85	68~85
標準フック	7.3t														
フック質量	300kg														
標準巻掛本数	1														

注) カウンタウエイト 15t、アウトリガ張出幅 6.2m

【1性能】

51.7mブーム+1.6m+フルオートラフィングジブ

単位:t

ジブ長さ 作業半径 (m)	7.4m					12.4m					17.4m				
	オフセット					オフセット					オフセット				
	5°	15°	30°	45°	60°	5°	15°	30°	45°	60°	5°	15°	30°	45°	60°
8.0	7.3														
9.0	7.3	7.3													
10.0	7.3	7.3				4.3					3.2				
11.0	7.3	7.3	7.3			4.3					3.2				
12.0	7.3	7.3	7.3	6.2		4.3	4.3				3.2				
14.0	7.3	7.3	7.3	6.0	4.5	4.3	4.3				3.2	3.1			
16.0	7.3	7.3	7.3	5.8	4.4	4.3	4.3	3.9			3.2	3.0			
18.0	7.3	7.3	7.0	5.7	4.3	4.3	4.3	3.8	3.1		3.2	2.8	2.3		
20.0	6.5	6.9	6.6	5.6	4.3	4.3	4.3	3.6	3.0	2.3	3.1	2.7	2.3		
22.0	5.1	5.5	5.9	5.4	4.3	4.3	4.2	3.5	2.9	2.3	3.0	2.6	2.2		
24.0	3.8	4.2	4.6	4.9	4.2	4.3	4.1	3.4	2.9	2.3	2.9	2.5	2.1	1.8	
26.0	2.8	3.1	3.5	3.8	3.9	3.6	3.9	3.3	2.8	2.3	2.8	2.4	2.0	1.7	1.4
28.0		2.2	2.6	2.8	2.9	2.7	3.1	3.2	2.7	2.2	2.7	2.3	2.0	1.7	1.4
30.0			2.0	2.0		1.9	2.3	2.9	2.7	2.2	2.6	2.3	1.9	1.6	1.4
32.0								2.1	2.5	2.2	1.9	2.2	1.9	1.6	1.4
34.0									1.8	1.9		1.8	1.8	1.6	1.4
36.0													1.8	1.5	1.4
38.0														1.5	1.4
θ(°)	65~85	64~85	66~85	66~85	66~85	65~85	68~85	70~85	69~85	68~85	67~85	70~85	71~85	70~85	68~85
標準フック	7.3t														
フック質量	300kg														
標準巻掛本数	1														

注) カウンタウエイト 15t、アウトリガ張出幅 6.2m

【性能】

56.0mブーム+1.6m+フルオートラフィングジブ

単位:t

ジブ長さ 作業半径 (m)	7.4m					12.4m					17.4m				
	オフセット					オフセット					オフセット				
	5°	15°	30°	45°	60°	5°	15°	30°	45°	60°	5°	15°	30°	45°	60°
9.0	6.3														
10.0	6.3	6.3													
11.0	6.3	6.3				4.3									
12.0	6.3	6.3	6.3			4.3					2.9				
14.0	6.3	6.3	6.3	6.0		4.3	4.3				2.9				
16.0	6.3	6.3	6.1	5.9	4.4	4.3	4.3	3.8			2.9	2.8			
18.0	6.3	6.0	5.7	5.6	4.4	4.3	4.3	3.7	3.1		2.9	2.8			
20.0	5.9	5.7	5.4	5.3	4.3	4.3	4.3	3.5	3.1	2.3	2.9	2.7	2.2		
22.0	5.3	5.4	5.2	5.1	4.3	4.3	4.1	3.4	3.0	2.3	2.9	2.6	2.1		
24.0	4.1	4.4	4.9	4.8	4.2	4.3	4.0	3.3	2.9	2.3	2.8	2.5	2.1	1.8	
26.0	3.1	3.4	3.8	4.1	4.2	3.8	3.8	3.2	2.8	2.3	2.7	2.4	2.0	1.7	1.4
28.0	2.2	2.5	2.8	3.1	3.2	2.9	3.3	3.1	2.8	2.2	2.7	2.3	2.0	1.7	1.4
30.0			2.0	2.2	2.3	2.1	2.5	3.0	2.7	2.2	2.6	2.2	1.9	1.6	1.4
32.0								2.4	2.7	2.2	2.1	2.2	1.9	1.6	1.4
34.0									2.0	2.2		2.0	1.8	1.6	1.4
36.0													1.8	1.5	1.4
38.0														1.5	1.4
θ(°)	66~85	67~85	67~85	68~85	69~85	67~85	70~85	72~85	71~85	71~85	69~85	73~85	74~85	73~85	71~85
標準フック	7.3t														
フック質量	300kg														
標準巻掛本数	1														

注) カウンタウエイト 15t、アウトリガ張出幅 6.2m

【性能】

60.0mブーム+1.6m+フルオートラフィングジブ

単位:t

ジブ長さ 作業半径 (m)	7.4m					12.4m					17.4m				
	オフセット					オフセット					オフセット				
	5°	15°	30°	45°	60°	5°	15°	30°	45°	60°	5°	15°	30°	45°	60°
9.0	5.3														
10.0	5.3														
11.0	5.3	5.3													
12.0	5.3	5.3				4.1									
14.0	5.3	5.3	5.3			4.1					2.8				
16.0	5.3	5.3	5.3	5.3		4.1	4.1				2.8	2.7			
18.0	5.3	5.3	5.3	5.1	4.4	4.1	4.1	3.6			2.8	2.6			
20.0	5.3	5.2	5.0	4.9	4.3	4.1	4.1	3.5	3.1		2.7	2.6	2.2		
22.0	5.1	4.9	4.7	4.6	4.3	4.1	4.0	3.4	3.0	2.3	2.7	2.5	2.1		
24.0	4.0	4.4	4.5	4.4	4.3	4.1	3.9	3.3	2.9	2.3	2.7	2.4	2.1		
26.0	3.0	3.3	3.7	4.0	4.2	3.7	3.8	3.2	2.9	2.3	2.6	2.4	2.0	1.7	
28.0			2.8	3.1	3.2	2.8	3.3	3.1	2.8	2.2	2.6	2.3	1.9	1.7	1.4
30.0					2.3		2.5	3.0	2.8	2.2	2.5	2.2	1.9	1.7	1.4
32.0								2.3	2.7	2.2		2.1	1.8	1.6	1.4
34.0										2.2			1.8	1.6	1.4
36.0														1.6	1.4
38.0															1.4
θ(°)	70~85	71~85	71~85	72~85	71~85	71~85	72~85	75~85	75~85	73~85	74~85	76~85	77~85	75~85	73~85
標準フック	7.3t														
フック質量	300kg														
標準巻掛本数	1														

注) カウンタウエイト 15t、アウトリガ張出幅 6.2m

フルオートラフィングジブ

【L性能】

43.0mブーム+1.6m+フルオートラフィングジブ

単位:t

ジブ長さ 作業半径 (m)	7.4m					12.4m					17.4m				
	オフセット					オフセット					オフセット				
	5°	15°	30°	45°	60°	5°	15°	30°	45°	60°	5°	15°	30°	45°	60°
6.0	7.3														
7.0	7.3					4.3									
8.0	7.3	7.3				4.3					3.3				
9.0	7.3	7.3	7.3			4.3					3.3				
10.0	7.3	7.3	7.3	6.2		4.3	4.3				3.3				
11.0	7.3	7.3	7.3	6.1	4.5	4.3	4.3				3.3	3.3			
12.0	7.3	7.3	7.3	6.0	4.5	4.3	4.3	4.3			3.3	3.3			
14.0	7.3	7.3	7.3	5.8	4.4	4.3	4.3	4.2			3.3	3.2			
16.0	7.3	7.3	7.3	5.7	4.4	4.3	4.3	4.0	3.1	2.4	3.3	3.1	2.5		
18.0	7.3	7.3	6.9	5.5	4.3	4.3	4.3	3.8	3.0	2.4	3.3	2.9	2.4		
20.0	7.3	7.3	6.7	5.4	4.3	4.3	4.3	3.7	3.0	2.3	3.3	2.8	2.3		
22.0	6.2	6.5	6.4	5.3	4.2	4.3	4.3	3.6	2.9	2.3	3.1	2.6	2.2	1.8	
24.0	4.9	5.2	5.6	5.2	4.2	4.3	4.1	3.4	2.8	2.3	3.0	2.5	2.1	1.7	1.5
26.0	3.8	4.1	4.4	4.7	4.2	4.3	3.9	3.3	2.7	2.2	2.8	2.4	2.1	1.7	1.4
28.0	2.8	3.1	3.4	3.6		3.7	3.8	3.2	2.7	2.2	2.7	2.3	2.0	1.6	1.4
30.0	2.0	2.3	2.5	2.7		2.9	3.3	3.1	2.6	2.2	2.6	2.2	1.9	1.6	1.4
32.0	1.4	1.6	1.8	1.9		2.2	2.5	3.0	2.6	2.2	2.5	2.2	1.8	1.5	1.4
34.0	0.8	0.9	1.1	1.2		1.6	1.9	2.3	2.5		2.2	2.1	1.8	1.5	1.4
36.0						1.0	1.3	1.6	1.8		1.7	2.0	1.7	1.5	1.4
38.0							0.8	1.1	1.2		1.2	1.6	1.7	1.5	
40.0											0.8	1.1	1.5	1.4	
θ(°)	48~85	50~85	52~85	54~85	67~85	52~85	51~85	56~85	57~85	66~85	52~85	57~85	61~85	62~85	68~85
標準フック	7.3t														
フック質量	300kg														
標準巻掛本数	1														

注) カウンタウエイト 28t、アウトリガ張出幅 5.0m

【L性能】

51.7mブーム+1.6m+フルオートラフィングジブ

単位:t

ジブ長さ 作業半径 (m)	7.4m					12.4m					17.4m				
	オフセット					オフセット					オフセット				
	5°	15°	30°	45°	60°	5°	15°	30°	45°	60°	5°	15°	30°	45°	60°
8.0	7.3														
9.0	7.3	7.3													
10.0	7.3	7.3				4.3					3.2				
11.0	7.3	7.3	7.3			4.3					3.2				
12.0	7.3	7.3	7.3	6.2		4.3	4.3				3.2				
14.0	7.3	7.3	7.3	6.0	4.5	4.3	4.3				3.2	3.1			
16.0	7.3	7.3	7.3	5.8	4.4	4.3	4.3	3.9			3.2	3.0			
18.0	7.3	7.3	7.0	5.7	4.3	4.3	4.3	3.8	3.1		3.2	2.8	2.3		
20.0	7.1	6.9	6.6	5.6	4.3	4.3	4.3	3.6	3.0	2.3	3.1	2.7	2.3		
22.0	6.4	6.5	6.3	5.4	4.3	4.3	4.2	3.5	2.9	2.3	3.0	2.6	2.2		
24.0	5.1	5.4	5.9	5.3	4.2	4.3	4.1	3.4	2.9	2.3	2.9	2.5	2.1	1.8	
26.0	4.0	4.3	4.7	5.0	4.2	4.3	3.9	3.3	2.8	2.3	2.8	2.4	2.0	1.7	1.4
28.0	3.1	3.3	3.7	3.9	4.0	3.8	3.8	3.2	2.7	2.2	2.7	2.3	2.0	1.7	1.4
30.0	2.3	2.5	2.8	3.0	3.1	3.0	3.4	3.1	2.7	2.2	2.6	2.3	1.9	1.6	1.4
32.0	1.6	1.8	2.1	2.2		2.3	2.6	3.0	2.6	2.2	2.5	2.2	1.9	1.6	1.4
34.0			1.4	1.5		1.7	2.0	2.4	2.6	2.2	2.3	2.1	1.8	1.6	1.4
36.0															
38.0											1.7	2.0	1.8	1.5	1.4
40.0												1.6	1.7	1.5	1.4
θ(°)	59~85	60~85	59~85	62~85	67~85	61~85	62~85	64~85	65~85	67~85	64~85	67~85	67~85	69~85	66~85
標準フック	7.3t														
フック質量	300kg														
標準巻掛本数	1														

注) カウンタウエイト 28t、アウトリガ張出幅 5.0m

【L性能】

56.0mブーム+1.6m+フルオートラフィングジブ

単位:t

ジブ長さ 作業半径 (m)	7.4m					12.4m					17.4m				
	オフセット					オフセット					オフセット				
	5°	15°	30°	45°	60°	5°	15°	30°	45°	60°	5°	15°	30°	45°	60°
9.0	6.3														
10.0	6.3	6.3													
11.0	6.3	6.3				4.3									
12.0	6.3	6.3	6.3			4.3					2.9				
14.0	6.3	6.3	6.3	6.0		4.3	4.3				2.9				
16.0	6.3	6.3	6.1	5.9	4.4	4.3	4.3	3.8			2.9	2.8			
18.0	6.3	6.0	5.7	5.6	4.4	4.3	4.3	3.7	3.1		2.9	2.8			
20.0	5.9	5.7	5.4	5.3	4.3	4.3	4.3	3.5	3.1	2.3	2.9	2.7	2.2		
22.0	5.6	5.4	5.2	5.1	4.3	4.3	4.1	3.4	3.0	2.3	2.9	2.6	2.1		
24.0	5.3	5.1	4.9	4.8	4.2	4.3	4.0	3.3	2.9	2.3	2.8	2.5	2.1	1.8	
26.0	4.3	4.6	4.7	4.6	4.2	4.3	3.8	3.2	2.8	2.3	2.7	2.4	2.0	1.7	1.4
28.0	3.3	3.6	3.9	4.2	4.2	4.0	3.7	3.1	2.8	2.2	2.7	2.3	2.0	1.7	1.4
30.0	2.5	2.8	3.1	3.3	3.4	3.2	3.6	3.0	2.7	2.2	2.6	2.2	1.9	1.6	1.4
32.0	1.8	2.0	2.3	2.5	2.6	2.5	2.8	3.0	2.7	2.2	2.5	2.2	1.9	1.6	1.4
34.0			1.7	1.8		1.9	2.2	2.6	2.6	2.2	2.4	2.1	1.8	1.6	1.4
36.0							1.6	2.0	2.3	2.2	1.9	2.0	1.8	1.5	1.4
38.0								1.5	1.7	1.8		1.8	1.7	1.5	1.4
40.0													1.7	1.5	1.4
θ(°)	62~85	64~85	63~85	64~85	68~85	64~85	65~85	67~85	67~85	67~85	66~85	71~85	71~85	72~85	69~85
標準フック	7.3t														
フック質量	300kg														
標準巻掛本数	1														

注) カウンタウエイト 28t、アウトリガ張出幅 5.0m

【L性能】

60.0mブーム+1.6m+フルオートラフィングジブ

単位:t

ジブ長さ 作業半径 (m)	7.4m					12.4m					17.4m				
	オフセット					オフセット					オフセット				
	5°	15°	30°	45°	60°	5°	15°	30°	45°	60°	5°	15°	30°	45°	60°
9.0	5.3														
10.0	5.3														
11.0	5.3	5.3													
12.0	5.3	5.3				4.1									
14.0	5.3	5.3	5.3			4.1					2.8				
16.0	5.3	5.3	5.3	5.3		4.1	4.1				2.8	2.7			
18.0	5.3	5.3	5.3	5.1	4.4	4.1	4.1	3.6			2.8	2.6			
20.0	5.3	5.2	5.0	4.9	4.3	4.1	4.1	3.5	3.1		2.7	2.6	2.2		
22.0	5.1	4.9	4.7	4.6	4.3	4.1	4.0	3.4	3.0	2.3	2.7	2.5	2.1		
24.0	4.8	4.7	4.5	4.4	4.3	4.1	3.9	3.3	2.9	2.3	2.7	2.4	2.1		
26.0	4.2	4.4	4.3	4.2	4.2	4.0	3.8	3.2	2.9	2.3	2.6	2.4	2.0	1.7	
28.0	3.3	3.5	3.9	4.1	4.1	3.8	3.6	3.1	2.8	2.2	2.6	2.3	1.9	1.7	1.4
30.0	2.5	2.7	3.0	3.3	3.4	3.1	3.5	3.0	2.8	2.2	2.5	2.2	1.9	1.7	1.4
32.0		2.0	2.3	2.5	2.6	2.4	2.8	2.9	2.7	2.2	2.5	2.1	1.8	1.6	1.4
34.0				1.8	1.9	1.8	2.1	2.6	2.7	2.2	2.3	2.1	1.8	1.6	1.4
36.0								2.0	2.3	2.2	1.8	2.0	1.7	1.6	1.4
38.0									1.7	1.8		1.7	1.7	1.5	1.4
40.0													1.7	1.5	1.4
θ(°)	66~85	66~85	67~85	67~85	67~85	66~85	69~85	72~85	70~85	69~85	69~85	72~85	74~85	72~85	71~85
標準フック	7.3t														
フック質量	300kg														
標準巻掛本数	1														

注) カウンタウエイト 28t、アウトリガ張出幅 5.0m

フルオートラフィングジブ

【M性能】

43.0mブーム+1.6m+フルオートラフィングジブ

単位:t

ジブ長さ 作業半径 (m)	7.4m					12.4m					17.4m				
	オフセット					オフセット					オフセット				
	5°	15°	30°	45°	60°	5°	15°	30°	45°	60°	5°	15°	30°	45°	60°
6.0	7.3														
7.0	7.3					4.3									
8.0	7.3	7.3				4.3					3.3				
9.0	7.3	7.3	7.3			4.3					3.3				
10.0	7.3	7.3	7.3	6.2		4.3	4.3				3.3				
11.0	7.3	7.3	7.3	6.1	4.5	4.3	4.3				3.3	3.3			
12.0	7.3	7.3	7.3	6.0	4.5	4.3	4.3	4.3			3.3	3.3			
14.0	7.3	7.3	7.3	5.8	4.4	4.3	4.3	4.2			3.3	3.2			
16.0	7.3	7.3	7.3	5.7	4.4	4.3	4.3	4.0	3.1	2.4	3.3	3.1	2.5		
18.0	7.3	7.3	6.9	5.5	4.3	4.3	4.3	3.8	3.0	2.4	3.3	2.9	2.4		
20.0	6.9	7.2	6.7	5.4	4.3	4.3	4.3	3.7	3.0	2.3	3.3	2.8	2.3		
22.0	5.4	5.8	6.2	5.3	4.2	4.3	4.3	3.6	2.9	2.3	3.1	2.6	2.2	1.8	
24.0	4.2	4.5	4.9	5.2	4.2	4.3	4.1	3.4	2.8	2.3	3.0	2.5	2.1	1.7	1.5
26.0	3.1	3.4	3.8	4.0	4.1	4.0	3.9	3.3	2.7	2.2	2.8	2.4	2.1	1.7	1.4
28.0	2.2	2.5	2.8	3.0		3.1	3.5	3.2	2.7	2.2	2.7	2.3	2.0	1.6	1.4
30.0	1.5	1.7	2.0	2.1		2.3	2.7	3.1	2.6	2.2	2.6	2.2	1.9	1.6	1.4
32.0		1.0	1.3	1.4		1.6	2.0	2.4	2.6	2.2	2.3	2.2	1.8	1.5	1.4
34.0						1.1	1.4	1.8	2.0		1.7	2.1	1.8	1.5	1.4
36.0								1.2	1.4		1.2	1.6	1.7	1.5	1.4
38.0												1.1	1.6	1.5	
40.0													1.1	1.3	
θ(°)	55~85	53~85	55~85	57~85	67~85	54~85	57~85	59~85	60~85	66~85	56~85	60~85	60~85	62~85	68~85
標準フック	7.3t														
フック質量	300kg														
標準巻掛本数	1														

注) カウンタウエイト 25t、アウトリガ張出幅 5.0m

【M性能】

51.7mブーム+1.6m+フルオートラフィングジブ

単位:t

ジブ長さ 作業半径 (m)	7.4m					12.4m					17.4m				
	オフセット					オフセット					オフセット				
	5°	15°	30°	45°	60°	5°	15°	30°	45°	60°	5°	15°	30°	45°	60°
8.0	7.3														
9.0	7.3	7.3													
10.0	7.3	7.3				4.3					3.2				
11.0	7.3	7.3	7.3			4.3					3.2				
12.0	7.3	7.3	7.3	6.2		4.3	4.3				3.2				
14.0	7.3	7.3	7.3	6.0	4.5	4.3	4.3				3.2	3.1			
16.0	7.3	7.3	7.3	5.8	4.4	4.3	4.3	3.9			3.2	3.0			
18.0	7.3	7.3	7.0	5.7	4.3	4.3	4.3	3.8	3.1		3.2	2.8	2.3		
20.0	7.1	6.9	6.6	5.6	4.3	4.3	4.3	3.6	3.0	2.3	3.1	2.7	2.3		
22.0	5.6	6.0	6.3	5.4	4.3	4.3	4.2	3.5	2.9	2.3	3.0	2.6	2.2		
24.0	4.4	4.7	5.1	5.3	4.2	4.3	4.1	3.4	2.9	2.3	2.9	2.5	2.1	1.8	
26.0	3.3	3.6	4.0	4.3	4.2	4.1	3.9	3.3	2.8	2.3	2.8	2.4	2.0	1.7	1.4
28.0	2.4	2.7	3.1	3.3	3.4	3.2	3.6	3.2	2.7	2.2	2.7	2.3	2.0	1.7	1.4
30.0	1.7	1.9	2.2	2.4	2.5	2.4	2.8	3.1	2.7	2.2	2.6	2.3	1.9	1.6	1.4
32.0			1.5	1.7		1.7	2.1	2.6	2.6	2.2	2.3	2.2	1.9	1.6	1.4
34.0							1.5	1.9	2.2	2.2	1.8	2.1	1.8	1.6	1.4
36.0									1.6	1.7		1.7	1.8	1.5	1.4
38.0													1.7	1.5	1.4
40.0														1.5	1.4
θ(°)	61~85	62~85	62~85	64~85	67~85	63~85	64~85	69~85	67~85	66~85	65~85	68~85	69~85	69~85	66~85
標準フック	7.3t														
フック質量	300kg														
標準巻掛本数	1														

注) カウンタウエイト 25t、アウトリガ張出幅 5.0m

【M性能】

56.0mブーム+1.6m+フルオートラフィングジブ

単位:t

ジブ長さ 作業半径 (m)	7.4m					12.4m					17.4m				
	オフセット					オフセット					オフセット				
	5°	15°	30°	45°	60°	5°	15°	30°	45°	60°	5°	15°	30°	45°	60°
9.0	6.3														
10.0	6.3	6.3													
11.0	6.3	6.3				4.3									
12.0	6.3	6.3	6.3			4.3					2.9				
14.0	6.3	6.3	6.3	6.0		4.3	4.3				2.9				
16.0	6.3	6.3	6.1	5.9	4.4	4.3	4.3	3.8			2.9	2.8			
18.0	6.3	6.0	5.7	5.6	4.4	4.3	4.3	3.7	3.1		2.9	2.8			
20.0	5.9	5.7	5.4	5.3	4.3	4.3	4.3	3.5	3.1	2.3	2.9	2.7	2.2		
22.0	5.6	5.4	5.2	5.1	4.3	4.3	4.1	3.4	3.0	2.3	2.9	2.6	2.1		
24.0	4.6	5.0	4.9	4.8	4.2	4.3	4.0	3.3	2.9	2.3	2.8	2.5	2.1	1.8	
26.0	3.6	3.9	4.3	4.6	4.2	4.3	3.8	3.2	2.8	2.3	2.7	2.4	2.0	1.7	1.4
28.0	2.7	3.0	3.3	3.6	3.7	3.4	3.7	3.1	2.8	2.2	2.7	2.3	2.0	1.7	1.4
30.0	1.9	2.2	2.5	2.7	2.8	2.6	3.0	3.0	2.7	2.2	2.6	2.2	1.9	1.6	1.4
32.0			1.8	2.0	2.0	1.9	2.3	2.8	2.7	2.2	2.5	2.2	1.9	1.6	1.4
34.0							1.7	2.1	2.4	2.2	1.9	2.1	1.8	1.6	1.4
36.0									1.8	1.9		1.8	1.8	1.5	1.4
38.0													1.7	1.5	1.4
40.0														1.5	1.4
θ(°)	64~85	66~85	65~85	66~85	67~85	65~85	66~85	71~85	69~85	69~85	68~85	72~85	72~85	72~85	69~85
標準フック	7.3t														
フック質量	300kg														
標準巻掛本数	1														

注) カウンタウエイト 25t、アウトリガ張出幅 5.0m

【M性能】

60.0mブーム+1.6m+フルオートラフィングジブ

単位:t

ジブ長さ 作業半径 (m)	7.4m					12.4m					17.4m				
	オフセット					オフセット					オフセット				
	5°	15°	30°	45°	60°	5°	15°	30°	45°	60°	5°	15°	30°	45°	60°
9.0	5.3														
10.0	5.3														
11.0	5.3	5.3													
12.0	5.3	5.3				4.1									
14.0	5.3	5.3	5.3			4.1					2.8				
16.0	5.3	5.3	5.3	5.3		4.1	4.1				2.8	2.7			
18.0	5.3	5.3	5.3	5.1	4.4	4.1	4.1	3.6			2.8	2.6			
20.0	5.3	5.2	5.0	4.9	4.3	4.1	4.1	3.5	3.1		2.7	2.6	2.2		
22.0	5.1	4.9	4.7	4.6	4.3	4.1	4.0	3.4	3.0	2.3	2.7	2.5	2.1		
24.0	4.6	4.7	4.5	4.4	4.3	4.1	3.9	3.3	2.9	2.3	2.7	2.4	2.1		
26.0	3.5	3.8	4.2	4.2	4.2	4.0	3.8	3.2	2.9	2.3	2.6	2.4	2.0	1.7	
28.0	2.6	2.9	3.3	3.5	3.7	3.3	3.6	3.1	2.8	2.2	2.6	2.3	1.9	1.7	1.4
30.0		2.1	2.5	2.7	2.8	2.5	2.9	3.0	2.8	2.2	2.5	2.2	1.9	1.7	1.4
32.0				1.9	2.0		2.2	2.7	2.7	2.2	2.4	2.1	1.8	1.6	1.4
34.0								2.1	2.4	2.2		2.1	1.8	1.6	1.4
36.0										1.9			1.7	1.6	1.4
38.0													1.7	1.5	1.4
40.0															1.4
θ(°)	68~85	68~85	69~85	68~85	69~85	70~85	71~85	73~85	74~85	71~85	73~85	75~85	75~85	73~85	71~85
標準フック	7.3t														
フック質量	300kg														
標準巻掛本数	1														

注) カウンタウエイト 25t、アウトリガ張出幅 5.0m

